

# **SNO-WAY**®

**SNOW & ICE CONTROL EQUIPMENT**

## **INSTALLATION & OWNER'S MANUAL**

**29, 29HD, 29T & 32 SERIES SNOW PLOWS  
WITH EIS® PLOW LIGHT HARNESS  
CONNECTIONS**

FOR GRAVITY & CENTRAL HYDRAULICS  
WITH SERIAL NUMBERS BEFORE:  
29G100300, 29TG100100, 32G100400, 32C100100  
WITH SERIAL NUMBER AFTER: 29G200000

FOR DOWN PRESSURE® HYDRAULICS  
WITH SERIAL NUMBERS BEFORE:  
29D102300, 29HDD100600, 29TD100400, 32D102800  
WITH SERIAL NUMBERS AFTER:  
29HDD200000, 32D200000

Sno-Way®, Down Pressure® and EIS® are registered trademarks of Sno-Way International, Inc.  
ProControl™, MegaBlade™, V-Wing™, E-Z Switch™, Revolution™, MaxAdjust™, SpeedLock™, and QuickJack™  
are trademarks of Sno-Way International, Inc.

©2009 Sno-Way® International

97101109H

# TABLE OF CONTENTS

	Page
INTRODUCTION .....	2
SAFETY .....	3
INSTALLATION INSTRUCTIONS .....	4
Electrical Installation .....	4
Mechanical Installation.....	5
Mounting Snow Plow To Vehicle.....	10
Installing The Cylinder Lock Clamp .....	12
Removing Snow Plow From Vehicle.....	13
MAINTENANCE .....	15
Break In Period.....	15
To Remove Excessive Free Play.....	15
Periodic Inspection .....	15
Plow Storage .....	15
Polycarbonate Blade Care.....	16
Polycarbonate Blade Cleaning Instructions.....	16
Fluid Requirements .....	16
Changing Oil and Cleaning Filter Screen .....	16
Cutting Edge.....	18
Disk Shoe Adjustment.....	18
Trip Spring Adjustment .....	18
Emergency Plow Raise.....	18
PLOWING OPERATION .....	19
Operating Class .....	19
Before the Season Begins.....	19
Transporting Vehicle With Plow Attached .....	19
Plowing Like A Pro.....	20
Using The Down Pressure (DP) Hydraulic Systems.....	20
Clearing Driveways .....	20
Clearing Parking Lots .....	20
TROUBLESHOOTING .....	21
Troubleshooting Quick Reference - General .....	21
Troubleshooting Charts.....	21
THEORY OF OPERATION .....	24
Hydraulic Power Unit .....	24
Hydraulic Controls .....	24
Electro-Hydraulic Operation .....	24
Raise Mode Of Operation .....	24
Lower Mode Of Operation - Gravity Down and Float .....	24
Down Pressure (DP) System.....	25
Angle Left or Right Mode of Operation .....	25
Fuse.....	25
MAIN WIRING HARNESS SCHEMATIC (Energy Interruption System) .....	26
HYDRAULIC SCHEMATIC (Gravity Down System) .....	27
HYDRAULIC SCHEMATIC (Down Pressure System) .....	28
WIRING SCHEMATIC (Gravity Down System) With S.N. Before: 29G100300, 29TG100100, 32G100400, 32C100100.....	29
WIRING SCHEMATIC (Down Pressure System) With S.N. Before: 26D102300, 29HDD100600, 29TDP100400, 32D102800.....	30
PROCONTROL WIRING SCHEMATIC With S.N. After 26G200000 .....	31
PROCONTROL WIRING SCHEMATIC With S.N. After 26D200000.....	32
TORQUE SPECIFICATIONS .....	33

# INTRODUCTION

This manual was written for the assembly, installation and maintenance of your new Sno-Way plow. Most importantly, this manual provides an operating plan for safe use. Refer to the Table of Contents for an outline of this manual.

Please keep this manual with your machine at all times as reference material and so it can be passed on to the next owner if the machine is sold.

We require that you read and understand the contents of this manual COMPLETELY, especially the chapter on SAFETY, before attempting any procedure contained in this manual.



The Society of Automotive Engineers has adopted this SAFETY ALERT SYMBOL to pinpoint characteristics that, if NOT carefully followed, can create a safety hazard. When you see this symbol in this manual or on the machine itself, BE ALERT!, your personal safety and the safety of others, is involved.

• Defined in the next column, are the SAFETY ALERT messages and how they will appear in this manual.

	WARNING
<p><b>FAILURE TO FOLLOW CAN RESULT IN INJURY OR DEATH.</b></p>	

	CAUTION
<p><b>Information, that if not carefully followed, can cause injury or damage to equipment!</b></p>	

*NOTE: Additional information concerning the equipment or the procedure that may or may not be contained elsewhere in this manual.*

**BE AWARE! It is illegal to remove, deface or otherwise alter the safety decals mounted on this equipment.**

Record the Power Pack Model Number, Power Pack Serial Number, Controller Serial Numbers, Blade Model Number, Blade Serial Number and the Pump Serial Number in the space provided below as a handy record for quick reference. The Power Pack Serial Number is located on the A-Frame (driver's side near the front), the Blade Serial Number is located on one of the middle ribs

of the blade. This plate contains information that your Dealer needs to answer questions or to order replacement parts, if needed, for your unit.

NAME PLATE DATA	
POWER PACK MODEL NUMBER _____	
POWER PACK SERIAL NUMBER _____ <small>(Located on A-Frame)</small>	
<b>CONTROLLER SERIAL NUMBERS:</b>	
TRANSMITTER S.N. _____	
RECEIVER S.N. _____	
BLADE MODEL NUMBER _____	
BLADE SERIAL NUMBER _____ <small>(Located on Blade Frame)</small>	
PUMP SERIAL NUMBER _____	
(FILL IN)	

DEALER	
NAME _____	
ADDRESS _____	
CITY _____ STATE _____ ZIP _____	
PHONE (    ) - _____	
(FILL IN)	

ORIGINAL PURCHASER	
NAME _____	
ADDRESS _____	
CITY _____ STATE _____ ZIP _____	
PHONE (    ) - _____	
(FILL IN)	

We reserve the right to make changes or improve the design or construction of any part(s) without incurring the obligation to install such parts or make any changes on any unit previously delivered.

Graphics and illustrations may be used which may show equipment and/or options not included in every installation without incurring the obligation to install such parts or make changes on units previously delivered.

Sno-Way Service Parts Manuals are available for purchase from your authorized Sno-Way dealer. Request part number 97100829 for the 29 & 32 Series Snow Plows. Factory contact information is available at [www.snoway.com](http://www.snoway.com).

Snow-Way Products are built under one or more of the following patents:

5,524,368	5,832,637	5,894,688	5,987,785	6,154,986
6,691,435	6,701,646	6,702,208	6,775,933	6,778,932
6,860,039	6,860,040	2,121,948		

# SAFETY

**BEFORE ATTEMPTING ANY PROCEDURE IN THIS BOOK, READ AND UNDERSTAND ALL THE SAFETY INFORMATION CONTAINED IN THIS SECTION. IN ADDITION, ENSURE ALL INDIVIDUALS WORKING WITH YOU ARE ALSO FAMILIAR WITH THESE SAFETY PRECAUTIONS.**

**For your safety Warning and Information Decals have been placed on this product to remind the operator to take safety precautions. It is important that these decals are in place and are legible before operation begins. New decals can be obtained from Sno-Way or your local dealer.**

**REMEMBER The careful operator is the best operator. Most accidents are caused by human error. Certain precautions must be observed to prevent the possibility of injury to operator or bystanders and/or damage to equipment.**

**NEVER** operate plow when under the influence of alcohol, drugs or other medications that could hamper your judgement and reactions. An accident may result in serious injury or death to other persons or yourself.

**ALWAYS** operate vehicle in a well-ventilated area. The carbon monoxide in exhaust gas is highly toxic and can cause serious injury or death.

**NEVER** allow hands, hair or clothing to get near any moving parts such as fan blades, belts and pulleys. Never wear neckties or loose clothing when working on the vehicle.

**NEVER** wear wrist watches, rings or other jewelry when working on the vehicle or individual equipment. These things can catch on moving parts or cause an electrical short circuit that could result in personal injury.

**ALWAYS** wear safety goggles when working on the vehicle to protect your eyes from battery acid, gasoline, and dust or dirt from flying off of moving engine parts.

**ALWAYS** be aware of and avoid contact with hot surfaces such as engine, radiator, and hoses.

**ALWAYS** wear safety glasses with side shields when striking metal against metal! In addition, it is recommended that a softer (non-chipable) metal material be used to cushion the blow. Failure to heed could result in injury to the eye(s) or other parts of the body.

**NEVER** allow children or unauthorized person to operate this unit.

**NEVER** exceed 45 m.p.h. when snow plow is attached to vehicle. Braking distances may be increased and handling characteristics may be impaired at speeds above 45 m.p.h.

**ALWAYS** lock the vehicle when unattended to prevent unauthorized operation of the plow.

**ALWAYS** check the job site for terrain hazards, obstructions and people.

**NEVER** exceed 10 m.p.h. when plowing. Excessive speed may cause serious injury and damage of equipment and property if an unseen obstacle is

encountered while plowing.

**ALWAYS** position blade so it does not block path of headlamps beam. Do not change blade positions while traveling. An incorrect plow position blocking headlamp beam may result in an accident.

**ALWAYS** check surrounding area for hazardous obstacles before operating this unit.

**ALWAYS** inspect the unit periodically for defects. Parts that are broken, missing or plainly worn must be replaced immediately. The unit, or any part of it should not be altered without prior written approval of the manufacturer.

**ALWAYS** insert the cylinder lock when plow is not in use. If the cylinder lock is not installed, the plow blade could inadvertently drop and cause injury.

**ALWAYS** shut off the vehicle engine, place the transmission in Neutral or Park, turn the ignition switch to the "OFF" position, firmly apply the parking brake of the vehicle and turn "OFF" the plow controller before attaching or detaching the blade from the vehicle or when making adjustments to the blade.

**ALWAYS** inspect lift system bolts and pins whenever attaching or detaching the plow, and before traveling. Worn or damaged components could result in the plow dropping to the pavement while driving, causing an accident.

**ALWAYS** keep hands and feet clear of blade and A-Frame when attaching or detaching plow.

**NEVER** place fingers in A-frame or mount lug holes to check alignment when attaching snow plow. Sudden motion of the plow could severely injure a finger.

**NEVER** stand between the vehicle and blade or directly in front of blade when it is being raised, lowered or angled. Clearance between vehicle and blade decreases as blade is operated and injury or death can result from blade striking a body or dropping on hands or feet.

**NEVER** work on the vehicle without having a fully serviced fire extinguisher available. A 5 lb or larger CO<sup>2</sup> or dry chemical unit specified for gasoline, chemical or electrical fires, is recommended.

**NEVER** smoke while working on the vehicle. Gasoline and battery acid vapors are extremely flammable and explosive.

**NEVER** use your hands to search for hydraulic fluid leaks; escaping fluid under pressure can be invisible and can penetrate the skin and cause injury! If any fluid is injected into the skin, see a doctor at once! Injected fluid MUST be surgically removed by a doctor familiar with this type of injury or gangrene may result.

**REMEMBER it is the owner's responsibility for communicating information on the safe use and proper maintenance of this machine.**

# INSTALLATION INSTRUCTIONS

## General

Install the subframe on the vehicle using the instructions supplied with the subframe package. The pin height should be 8" - 10" off the ground. (See Figure 1-1).

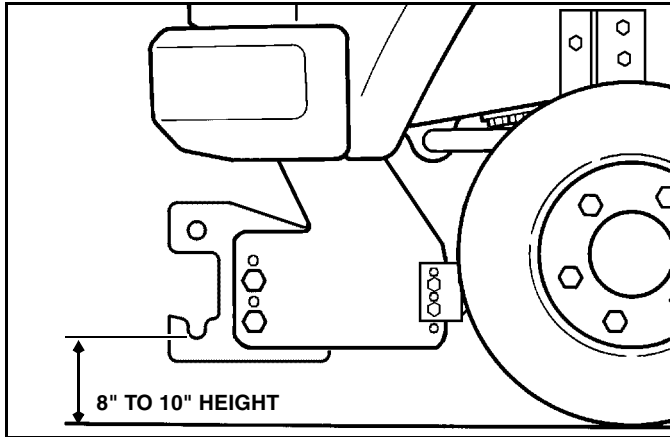

Figure 1-1

## Electrical Installation

1. Remove the battery power harness and power harness parts bag from the power pack carton.

*NOTE: Take extra time needed to plan the routing of wiring harnesses. Make sure harnesses do not interfere with, or contact, any moving parts and route wires away from excessive heat areas. Read all the instructions carefully to ensure a safe and professional installation.*

## WARNING

**Disconnect the vehicle NEG. (-) battery cable while performing steps 2 - 5 to avoid serious bodily injury from electrical shock, fire, or explosion. Do not re-connect battery cable until indicated in step 8.**

**FAILURE TO FOLLOW CAN RESULT IN INJURY OR DEATH**

2. Mount the fuse holder near the battery using (2) #10 x 1" self-tapping screws.

3. Take the cover off of the fuse holder and remove the nuts on the studs. Place one end of the 2 ft. long power wire on one stud. (See Figure 1-2).

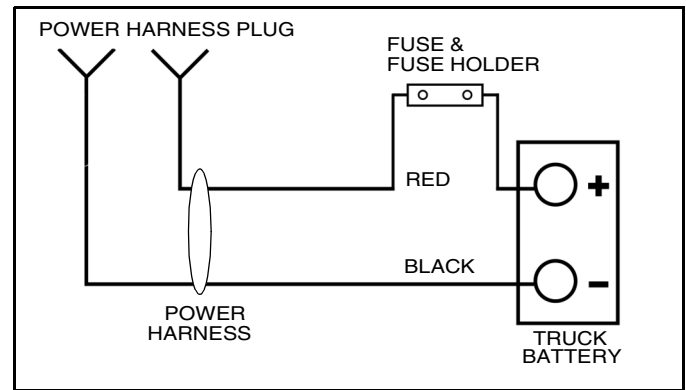

Figure 1-2

4. Attach the other end of one 2 ft. long power wire to the positive terminal on the battery.

5. Attach the power harness red wire to the other terminal of the fuse holder.

6. Place the fuse between the two studs and replace the nuts and cover.

7. Route power harness to convenient point on front of vehicle for connection to plow.

8. Attach the power harness black wire to the NEG. (-) terminal of the battery and re-connect the negative battery terminal.

9. Spray all terminal connections with a battery terminal protective coating.

10. Secure harness with plastic tie straps.

11. Install truck control harness if needed, using instructions included with controls.

12. Remove the main light harness from the power pack carton. Route the harness from the headlights to the front of the truck and through the grille or bumper. The ends with the green plugs go to the headlights and the ends with the black plugs go to the front of the truck.

13. Open the adapter harness bag, remove the harness and plug the proper adapters into the green plugs on the main harness. Connect the adapters to the truck wiring following the included instructions.

14. Secure the main harness and adapters. Make sure that the harnesses are not in contact with moving or hot engine parts.

15. Plug the male and female black plugs at the front of the truck together. These must be connected to allow the truck lights to operate.

## WARNING

Failure to connect the main light harness on the truck when plow is not attached will cause truck lights to not operate, which could cause an accident.

**FAILURE TO FOLLOW CAN RESULT IN INJURY OR DEATH.**

16. Apply included dielectric grease to all connectors.

*NOTE: An adapter is recommended for vehicles with a side post battery. (See Figure 1-3). (Adapters can be purchased from your Sno-Way dealer, Part #96100773)*

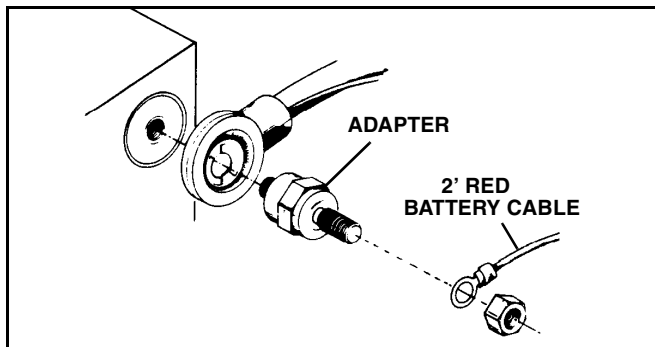

Figure 1-3

## Mechanical Installation

**IMPORTANT:** Graphics and illustrations may be used which may show equipment and/or options not included in every installation.

### Assemble Blade, Swing Frame and Trip Springs (29, 29HD, & 32 Series)

1. Open the power pack carton, remove the blade parts bag (part number 96106088, 32 Series or 96107662, 29, & 29HD Series) and the trip stop bag (part number 96107396, 32 Series or 96107395, 29 & 29HD Series). Face plates are in the bag with the stop blocks.

2. Slide the metal face plates into the slot in the blade stops from the side. Place the stops between the lugs on the swing frame. Secure with 3/8" x 2-1/2" bolts and locking nuts. (See Figure 1-4a). or Figure 1-4b Bolts and nuts are in the blade parts bag.

*NOTE: The 29 Series blade uses green stops and the 32 Series blade uses black stops. Make sure the proper stops are installed for the blade being used.*

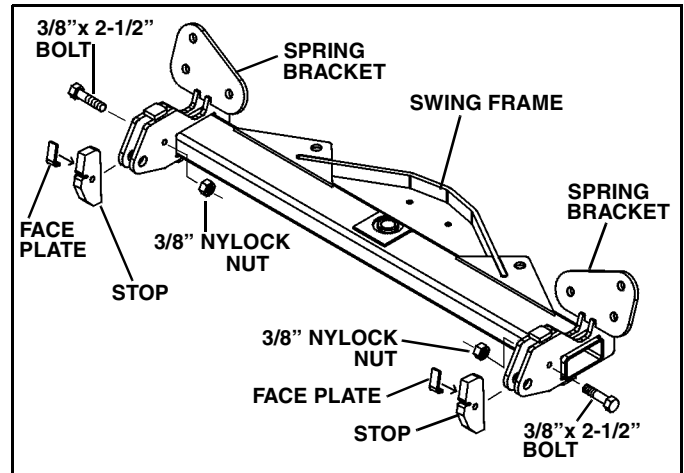

Figure 1-4a (Old Swing Frame)

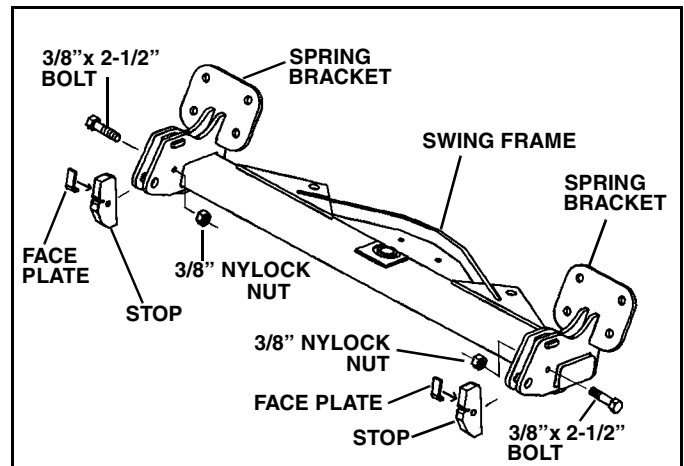

Figure 1-4b (New Swing Frame - Forwards and Backwards Compatible)

3. Lay blade face down on floor, using cardboard or similar material to prevent paint damage.

4. Place swing frame on blade and insert 3/4" x 2" clevis pin from blade parts bag. The ribs on either side of the center rib should be between the swing frame lugs. (See Figure 1-5).

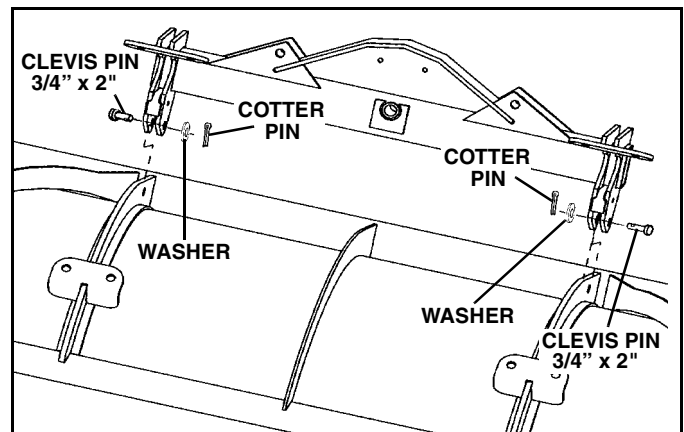

Figure 1-5

5. Insert washer on end of clevis pin and secure pin with cotter pin.

NOTE: Make sure cotter pin is properly bent or pin may work loose (See Figure 1-6).

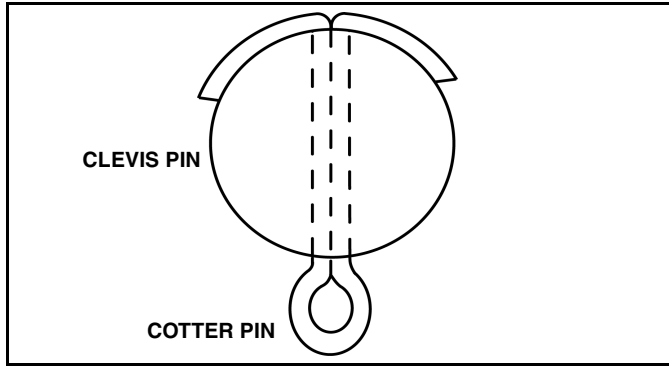

Figure 1-6

6. Remove the springs from the power pack carton. Two springs are needed for a 29 & 29HD Series blade and four are needed for a 32 Series blade.

7. Hook springs onto blade with open end of loop facing up. (See Figure 1-7a, Figure 1-7b and Figure 1-7c)

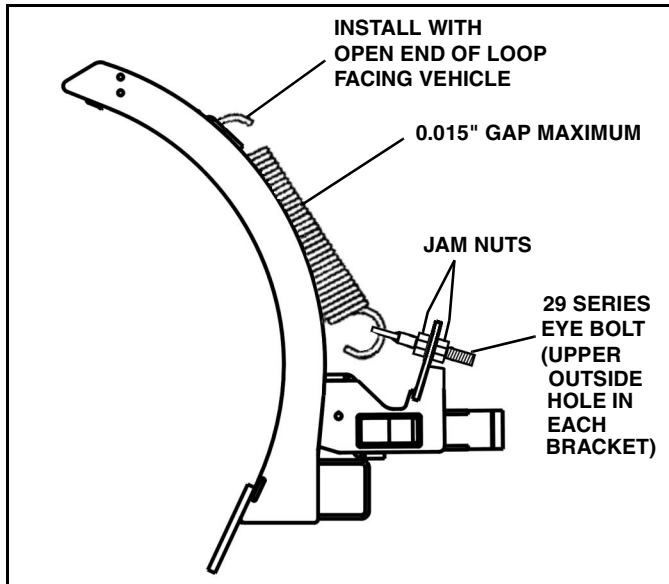

Figure 1-7a (29 Series)

8a. **29 and 29HD SERIES BLADES:** Hook other end of spring onto eyebolt. Insert one eyebolt on each side of the blade into the single upper hole on the swing frame spring bracket. Use a jam nut on either side of bracket to secure. (See Figure 1-7a and Figure 1-7b)

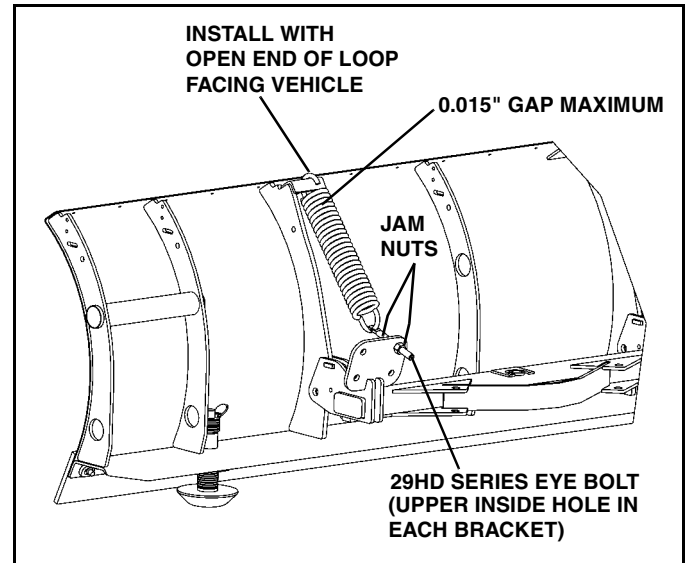

Figure 1-7b (29 HD Series)

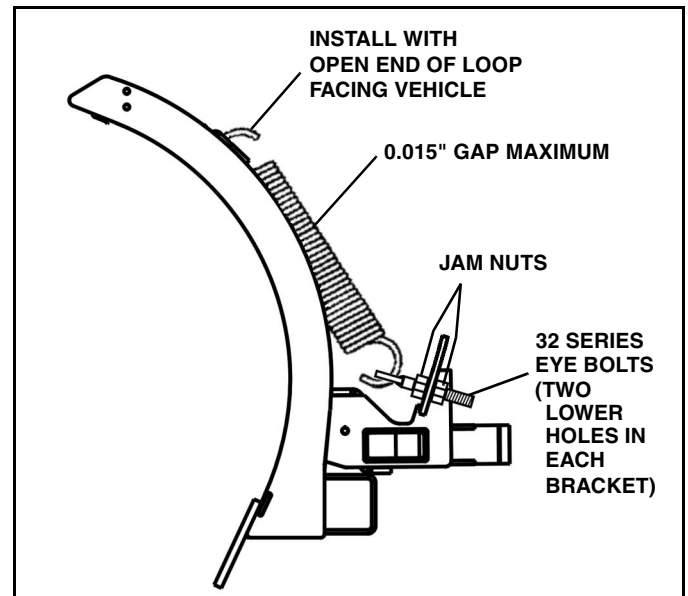

Figure 1-7c (32 Series)

8b. **32 SERIES BLADE ONLY:** Hook other end of spring onto eyebolt. Insert two eyebolts on each side of the blade into the two lower holes on the swing frame spring bracket. Use a jam nut on either side of bracket to secure. (See Figure 1-7c).

9. Tighten springs until a .010" feeler gauge can pass between two or more coils (a 3x5 postcard is approximately .010").

## CAUTION

Do not over tighten springs. If more than .015" (1/64") gap appears between coils damage could occur during plowing.

Spring must be installed with open end of top loop facing vehicle. Bottom loop position will vary.

### Assemble Blade, Swing Frame and Trip Springs (29T Series)

1. Open the power pack carton and remove the blade parts bag (part number 96107946).
2. Lay blade face down on floor, using cardboard or similar material to prevent paint damage.
3. Assemble swing frame to blade (See Figure 1-8.):  
(The long ribs of the swing frame will fit between the double ribs on the top portion of the blade).  
Remove contents from parts bag, insert (6) 1/2"-13 x 1-3/4" hex cap screws through the holes in the blade ribs and the corresponding holes in the swing frame and secure loosely with (6) 1/2" nylock nuts.  
Secure the blade to the swing frame at the hinge points with (2) 3/4" x 2-1/2" clevis pins, install washers over the ends of the clevis pins and secure with cotter pins.

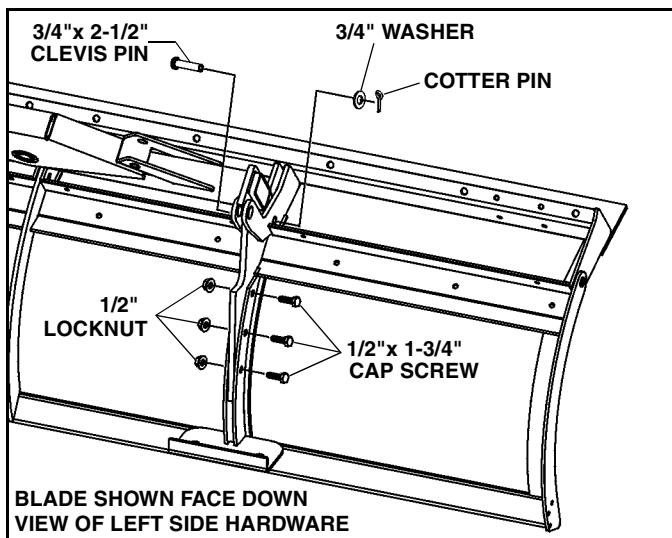

Figure 1-8

*NOTE: Make sure cotter pin is properly bent or pin may work loose (See Figure 1-9).*

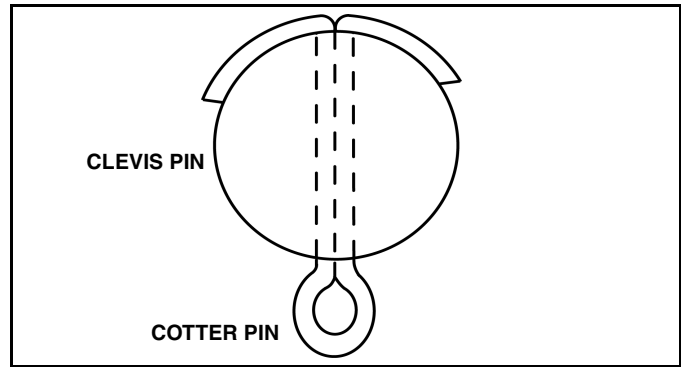

Figure 1-9

4. Tighten the nylock nuts at the rib connections.

5. Assemble the trip springs (See Figure 1-10.):  
Remove the (4) saddle assemblies, (4) threaded rods and (12) 3/4"-10 hex nuts from the kit box. Run (3) nuts onto the longer threaded end of each of the threaded rods, far enough to have about 3/4" of thread showing at the end. Screw the rod firmly into the saddle assembly and lock the last hex nut against it. Ensure that the two remaining nuts are run up against the saddle locking nut. Repeat for all rods.  
Remove the (8) spring cups and (4) springs from the box. Place (1) spring cup over one of the threaded rods, with the cup facing away from the nuts. Place (1) spring over the rod and locate it into the cup, then place another spring cup on the rod, locating it over the end of the spring. Repeat for all rods.

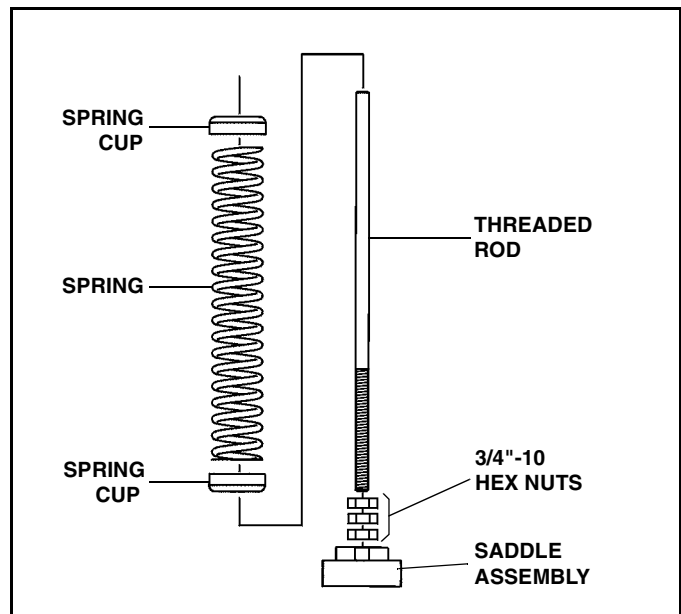

Figure 1-10

6. Stand the blade assembly up onto the wearstrip, forcing the lower blade as far forward as it will go. Chock the back of the swing frame up by approx. 8" to support the blade upright.

7. Fit the trip spring assemblies to the blade (See Figure 1-11).):

Remove (2) 1"-8 x 11-1/2" hex bolts, (2) 1"-8 locking nuts and (2) shock bushings from the kit box. Enter the end of the rod of one of the spring assemblies through the outermost of the holes of the upper blade spring brackets. While holding the spring assembly hard up against the spring bracket, push the 1" bolt through the saddle, just entering it into the outermost of the holes of the upper blade spring brackets. While holding the spring assembly hard up against the spring bracket, push the 1" bolt through the saddle, just entering it into the outermost rib of the lower blade lever-arm. Locate (1) shock bushing between the lower blade lever-arm ribs and align it with the 1" bolt hole, then push the 1" bolt through the shock bushing enough to protrude beyond the lever-arm by about 1/2". Now locate a second spring assembly into the inner hole of the upper blade spring bracket and locate the saddle over the protruding bolt. Push the bolt all the way through the saddle assemblies, holding the inner saddle in place, and fit the 1" lock nut. Tighten the locknut onto the bolt sufficiently to loosely hold the saddle assemblies against the lever-arm ribs. Repeat on the other side of the swing frame.

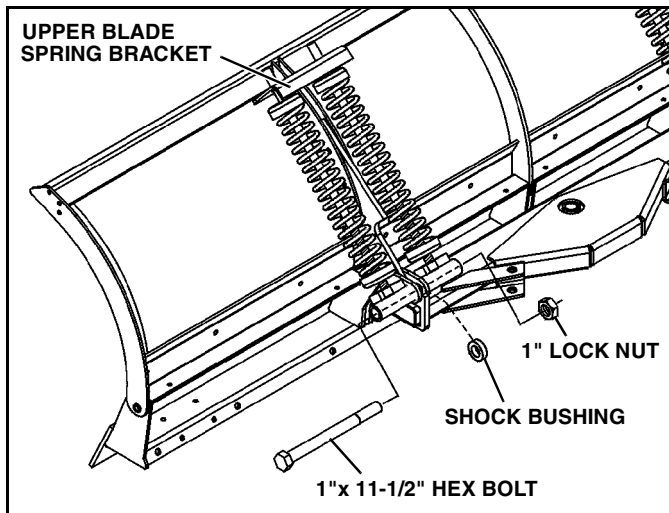

Figure 1-11

8. Adjust the trip spring loading (See Figure 1-12).):  
Screw the 3/4" nut, adjacent to the lower spring cup, along the threaded rod so as to compress the spring to an overall compressed length of 16", measured over the spring cups. Run the remaining nut up to the underside of the adjusting nut and firmly lock them together. Repeat for all spring assemblies.

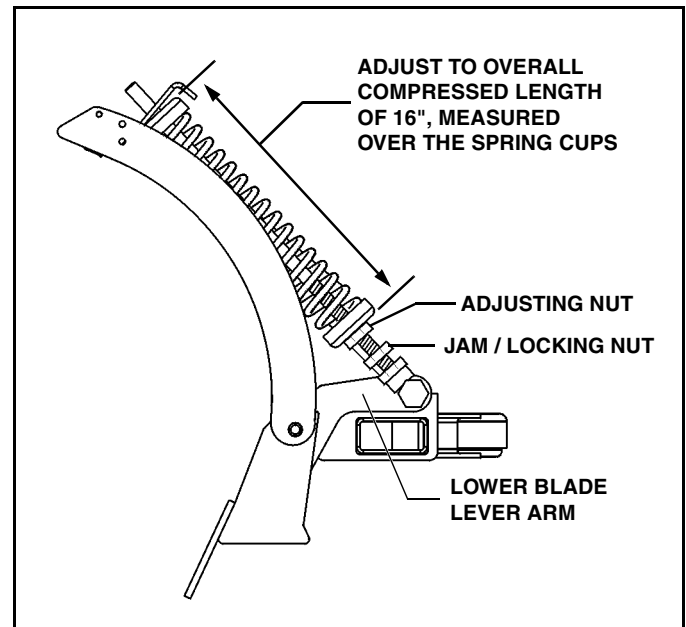

Figure 1-12

### Complete Installation (All Series)

1. Remove power unit from carton. Remove pump cover. Install receiver using instructions included with the controls package. Fill reservoir on pump with supplied hydraulic fluid.
2. Set lower hitch pins into slot on truck subframe. Plug in power and control harness and rotate light/lift bar into position. Lock in place by rotating cam handles. Set A-frame level using plow control. See "Mounting Snow Plow To Vehicle" on page 10 for more information.
3. Remove 1" locknut and bolt. Slide swing frame into A-frame. Replace 1" bolt and locknut and tighten. (See Figure 1-13). and Figure 1-14

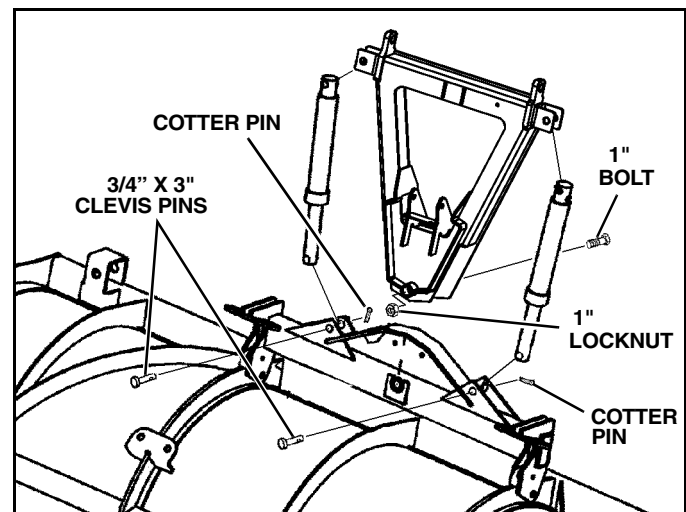

Figure 1-13

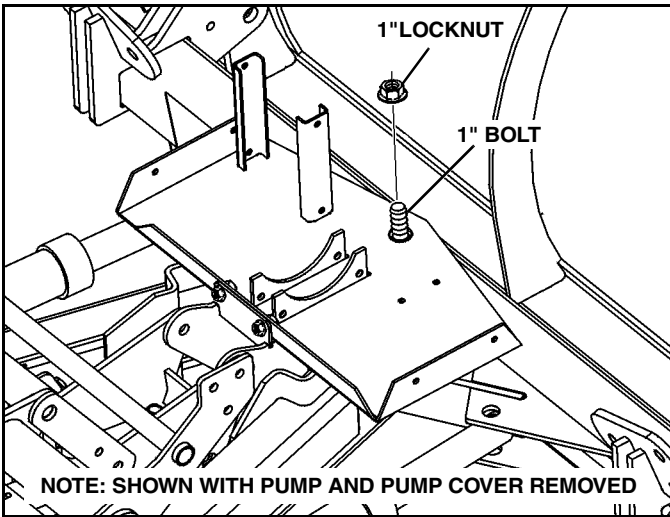

Figure 1-14

4. Remove cotter pins and 3/4" clevis pins from rod end of cylinders. Extend cylinders using plow control to align holes in cylinder rod and swing frame. Insert 3/4" clevis pins and secure with cotter pins. (See Figure 1-13). Bend cotter pin as shown in Figure 1-6 to prevent it from working loose.

5. Cycle all plow functions and refill reservoir. Repeat until all air is removed from hydraulic system.

6. Replace and tighten pump cover.

7. Install side marker into pre-drilled holes on blade frame using hardware included in package.

8. Install optional deflector, if equipped.

9. Remove left and right light support from power pack carton. Secure each light bar support to lift/light bar with (4) 3/8" x 1" screws, (8) washers and (4) lock nuts from the light bar parts bag, part number 96106089. Do not tighten at this time. (See Figure 1-15).

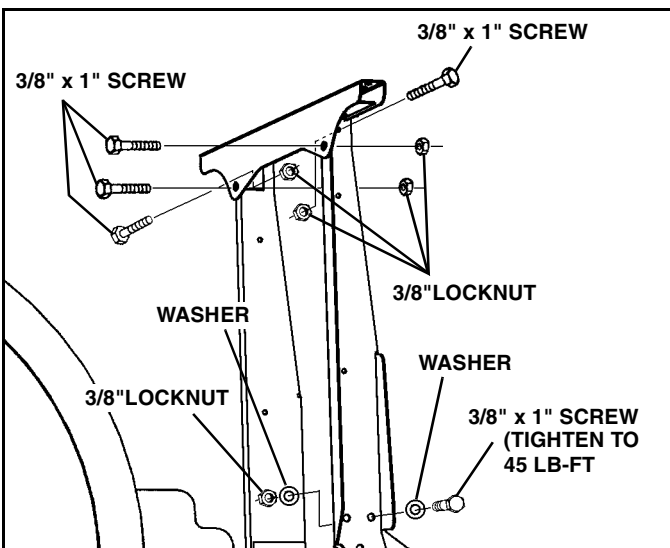

Figure 1-15

10. Secure light bar to supports with (4) 3/8" x 1" screws and lock nuts. Align light bar supports to vertical position and tighten all light bar hardware. Tighten eight lower screws to 45 lb-ft. (See Figure 1-15).

Mount lamps on light bar using supplied 1/2" lock washers and nuts. (See Figure 1-16).

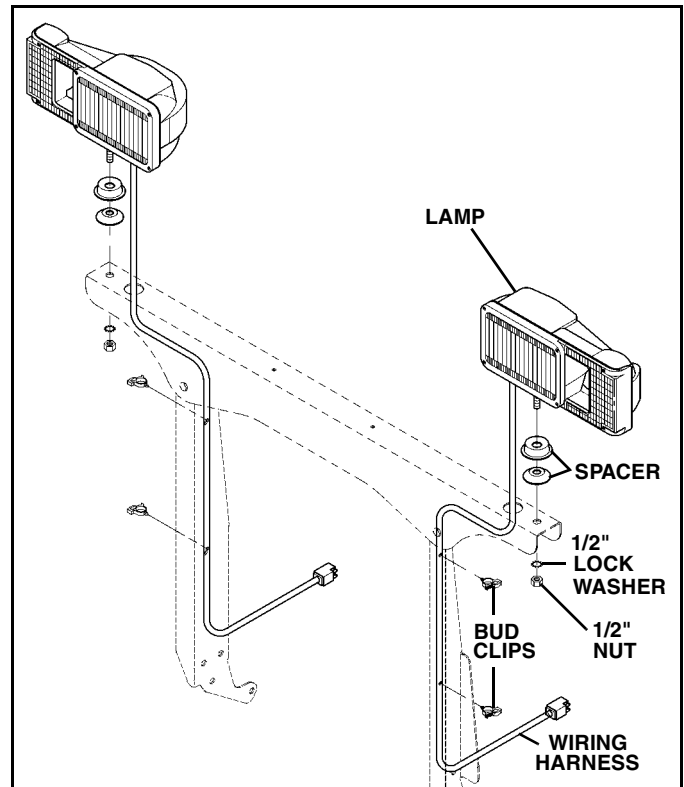

Figure 1-16

11. Route the harnesses through the light bar, through the access hole and down the inside of the light bar supports. (See Figure 1-16).

12. Check for proper light operation and aim plow lights with plow in up position.

13. Apply included dielectric grease to all light harness connections.

*NOTE: In order to conform to Federal Motor Vehicle Safety Standards a SAE J602 Approved aiming device must be used to aim plow lights.*

## Mounting Snow Plow To Vehicle

1. Drive truck into plow. Align light/lift bar frame inside of subframe lugs. Pins should fit inside slots cut into subframe lugs. (See Figure 1-17).

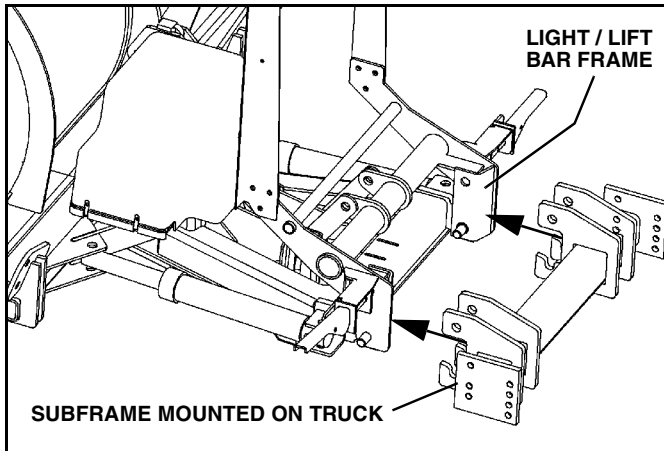

Figure 1-17

*NOTE: If pins are too high or low to fit into slots on subframe, adjust the height by plugging in the plow and hand held controller. **For Down Pressure Plows** - To lower the pins, turn on down pressure and press down. To raise the pins, press up. **For Gravity Plows** - To lower the pins, place plow in float and push up on light bar. To raise the pins, press up.*

### WARNING

When using the hand held controller to raise or lower the plow A-frame for mounting the plow to the vehicle, be especially careful of the movement of the light bar. This movement will occur when raising or lowering the A-frame or jack stand.

**FAILURE TO FOLLOW CAN RESULT IN INJURY OR DEATH**

### WARNING

Pressing the blade angle functions will result in the A-frame swinging if it is not secured to the truck. Do not press the angle function during plow installation.

**FAILURE TO FOLLOW CAN RESULT IN INJURY OR DEATH**

2. Plug in power harness and remove controller from truck cab. Plug controller into plow.

### WARNING

The power cable in front of the truck is wired directly to the battery. The power cable is always energized, even if the truck is turned off. Always replace the protective cap after disconnecting the plow power cable. Allowing an unprotected plug to contact metal parts of the truck may cause electrical component damage. Never use a metal object to clean the plug contacts.

**FAILURE TO FOLLOW CAN RESULT IN INJURY OR DEATH**

3. Rotate light/lift bar into position by turning on down pressure and pressing the lower button. (See Figure 1-18).

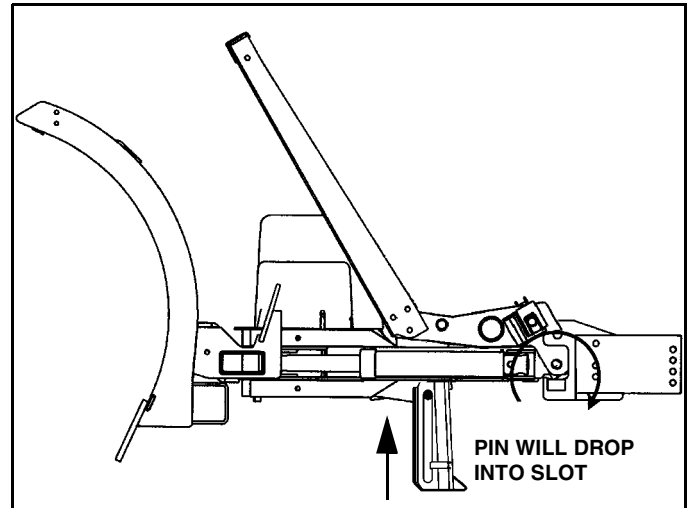

Figure 1-18

*NOTE: If your plow is not equipped with down pressure hydraulics you will have to manually rotate the light / lift bar into position by placing plow in float mode and pushing on the light bar.*

4. Put plow into float position by turning down pressure off. Rotate pin handles down to lock pins in place. (See Figure 1-19).

## WARNING

Make sure that upper hitch pins are engaged before moving truck. Hitch pins not fully engaged could result in the plow separating from the truck.

**FAILURE TO FOLLOW CAN RESULT IN INJURY OR DEATH**

*NOTE: Upper hitch pins are fully engaged when pin handle is tight against pin bracket and you cannot see the upper hitch pin between the pin bracket and pin handle.*

*If upper hitch pins are not fully engaged:*

*A. Raise plow an inch off the ground, then lower. Or,*

*B. Turn Down Pressure ON and then OFF.*

*Upper hitch pins will snap into place.*

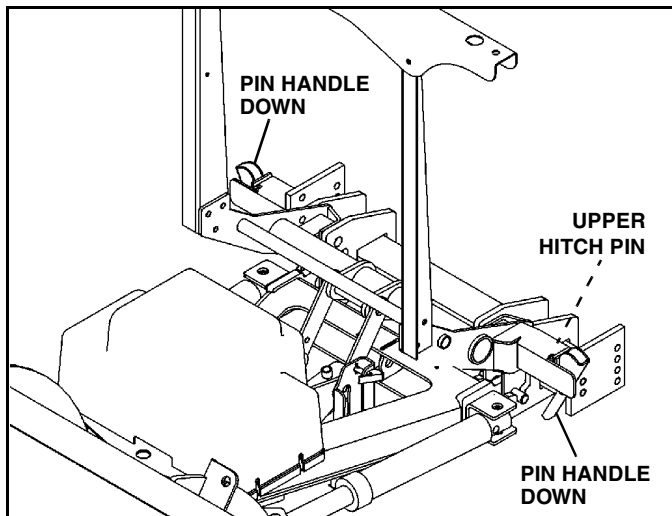

Figure 1-19

5. Unplug plow from control.

6. Disengage both jack stand pins by pulling on handles. Raise the jack stand and engage the bottom pin by pushing on the handle. Make sure pin is engaged in hole by rotating jack stand back and forth. (See Figure 1-20).

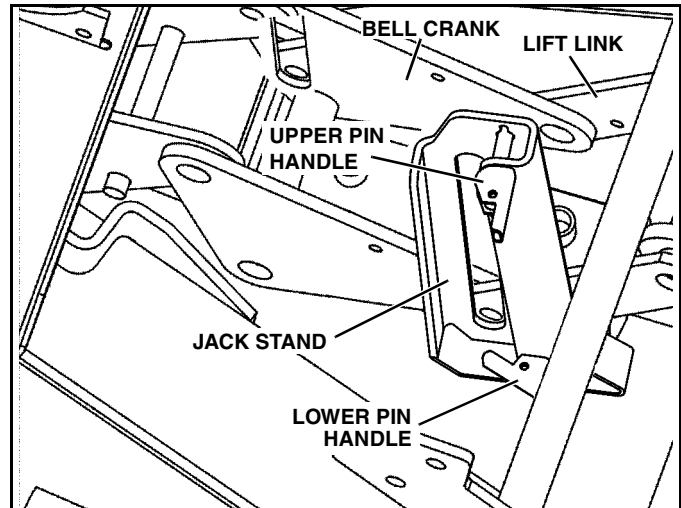

Figure 1-20

## CAUTION

Many new vehicles are equipped with onboard circuit sensors designed to display a dashboard LED when a headlight fails. Generally, these sensors are activated or tripped any time the circuit is being called upon to function while the headlight circuit is incomplete. This means that if a headlight fails while the headlight is in operation, the sensor will trip and the dashboard indicator will light up. It also means that if a headlamp socket is left empty—or a faulty lamp is installed—and the circuit is then activated, the sensor will trip and the dashboard indicator will light up.

These headlight circuit sensors are often engineered with pre-designated failure limits. This means that a sensor may be tripped a limited number of times. After that limit is reached the sensor may need to be reset by the dealer or replaced by the manufacturer.

Sno-Way EIS plow light systems essentially operate through a planned interruption of the headlight circuit. When the truck-side connectors are detached from one another, the vehicle headlamps are disconnected from the truck circuits which otherwise power them. Until those truck-side connectors are attached to the plow-side light connectors, the truck-side circuits are open. This means that if the truck's onboard sensors are active while the plow lights are being attached to the truck, the truck's sensors may trip.

## CAUTION

To avoid unnecessarily tripping the truck's sensor, every time the plow lights are being attached to the truck circuits or the truck circuits are being reattached to the vehicle lights, the truck's lights should be turned off.

Due to the aforementioned concerns, operators of vehicles equipped with EIS lights should make themselves aware of whatever circuit sensors may be installed on their vehicles. Operators should further become familiar with their vehicle manufacturer's description of how their truck's sensors are actuated or tripped. Finally operators should know whether predesignated failure limits may be engineered into their truck's sensors and what repair or replacement procedures are recommended should those limits be reached. Currently, the vehicle models affected are as follows:

**2006 and later-Dodge Dakota and Durango - All packages.**

**2006 and later-Dodge 1500, 2500 and 3500- All packages.**

**2008 Ford F250-F550 - All packages.**

7. Unplug light harness connectors on truck, and disconnect plow light connectors, which had been plugged together for corrosion protection during storage. (See Figure 1-21).

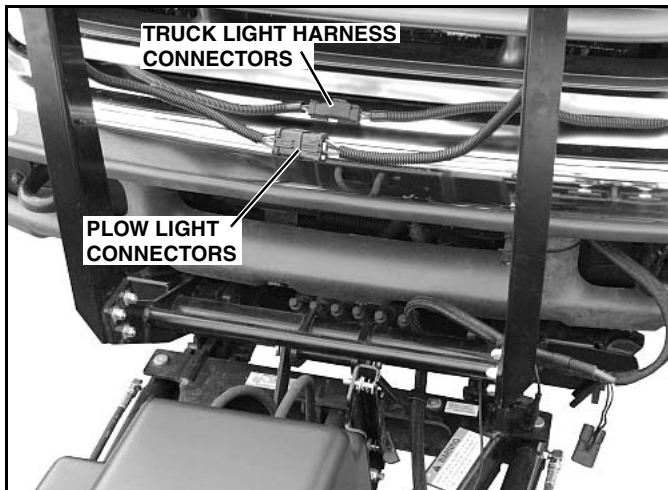

Figure 1-21

8. Plug plow light connectors into mating connectors on truck light harness. (See Figure 1-22).



Figure 1-22

## WARNING

Failure to properly connect plow lights to vehicle light harness will prevent plow lights from functioning. Follow proper procedure to connect light harnesses and test lights before operating.

**FAILURE TO FOLLOW CAN RESULT IN INJURY OR DEATH**

9. Plug control harness on plow into truck. Plug plow control inside truck cab.

10. Raise, lower and angle plow to make sure no hoses or wires pinch in the plow mechanism.

## Installing The Cylinder Lock Clamp

## WARNING

Always install the cylinder lock clamp when the plow blade is raised and the operator is not engaged in plowing operations. Equipment failure or inadvertent operation of the plow control while driving could allow the plow blade to fall, resulting in injury.

**FAILURE TO FOLLOW CAN RESULT IN INJURY OR DEATH**

1. Raise the plow to the full UP position.
2. Turn the ignition OFF and apply the parking brake.
3. Turn OFF the hand-held controller.
4. Remove the pin from the cylinder lock clamp.

5. Position the cylinder lock clamp around the exposed (chrome) portion of the lift cylinder with the open side of the cylinder lock up. Install the pin. (See Figure 1-23).

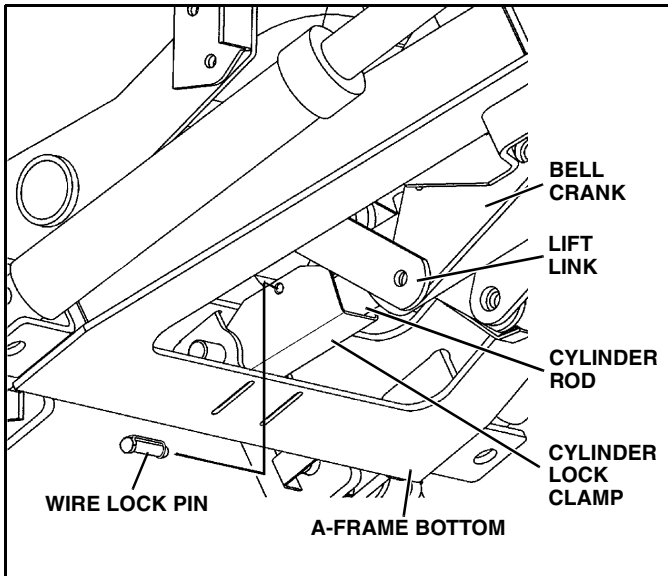

Figure 1-23

6. Lower the plow so that cylinder lock clamp is tight against cylinder.

## WARNING

Failure to lower plow onto clamp could block headlights resulting in an accident.

**FAILURE TO FOLLOW CAN RESULT IN INJURY OR DEATH**

## Removing Snow Plow From Vehicle

Choose a location for the plow storage, which will allow the plow to be removed from the vehicle and not be moved after removal. Also, choose a location that will not allow the plow stand to sink into the ground. A dry, protected area is recommended.

1. Lower plow to the ground, put vehicle in park, turn off the engine and set the parking brake.

2. Disconnect the plow lights from the truck light harness. (See Figure 1-24). Disconnect the plow control harness and replace the protective cap. (See Figure 1-26 or 1-27).

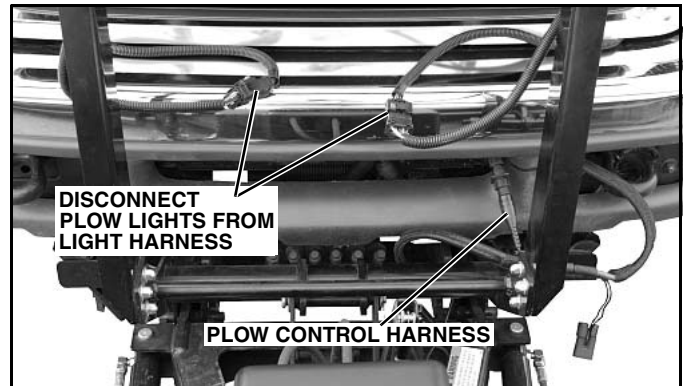

Figure 1-24

3. To prevent corrosion on the contacts, plug the male and female connectors on the plow together. (See Figure 1-25).

4. To make the truck lights operable, plug the male and female connectors on the truck light harness together. (See Figure 1-25).

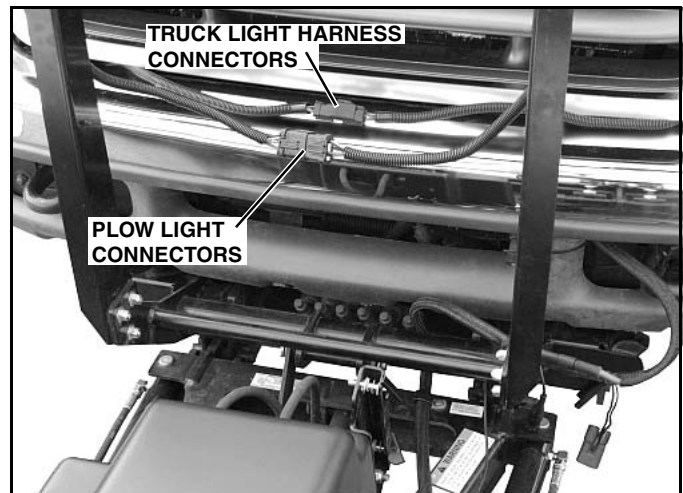

Figure 1-25

## WARNING

Failure to reconnect the main light harness on the truck when removing plow will cause truck lights to not operate, which could cause an accident. Test lights before operating.

**FAILURE TO FOLLOW CAN RESULT IN INJURY OR DEATH**

# CAUTION

When disconnecting the plow control harness, turn only the locking nut at the end of the connector. Do not turn the threaded boot. Turning the threaded boot will break the wires in the harness and cause the controller to stop functioning. (See Figure 1-26).

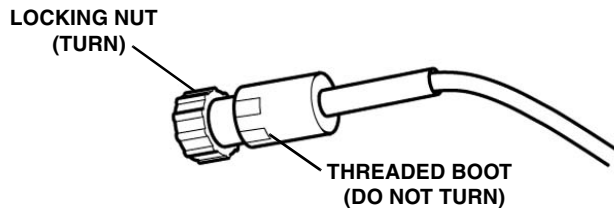

WITH S.N. BEFORE:  
29G100300, 29TG100100, 32G100400, 32C1001000,  
29D102300, 29HDD100600, 29TDP100400, 32D102800

Figure 1-26

7. Disengage lower jack stand pin by pulling on handle. Lower the jack stand and engage the top pin by pushing on the handle. Make sure pin is engaged in hole by rotating jack stand back and forth (See Figure 1-29).

8. Remove controller from truck cab and plug into plow control harness.

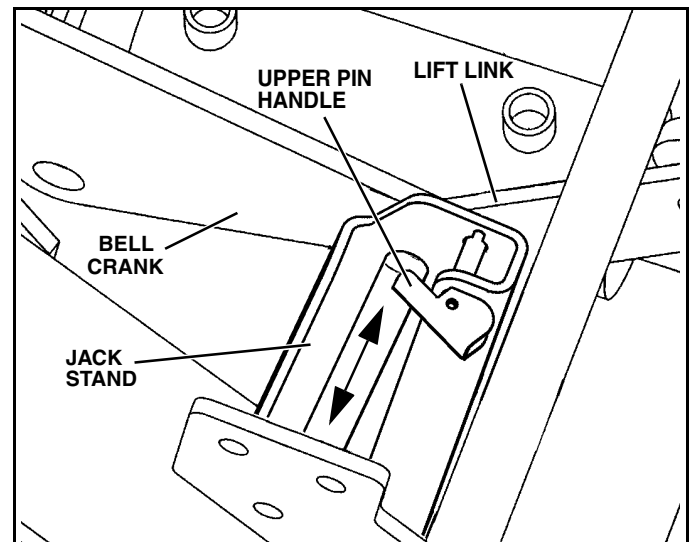

Figure 1-29

9. Rotate jack stand down and raise A-frame by pressing the up button. (See Figure 1-30).

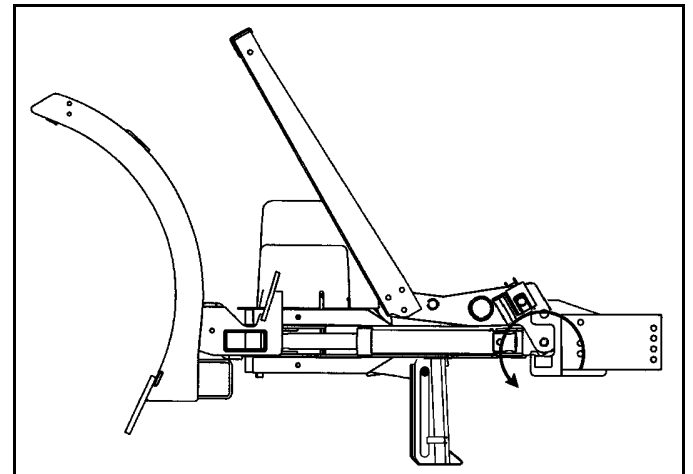

Figure 1-30

5. Turn Down Pressure ON and then OFF.

6. Rotate pin handles up (straight out) to unlock main pins. (See Figure 1-28).

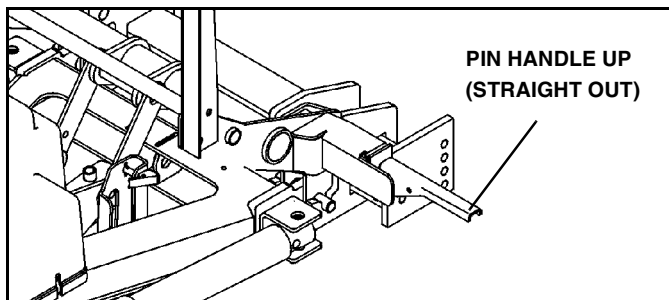
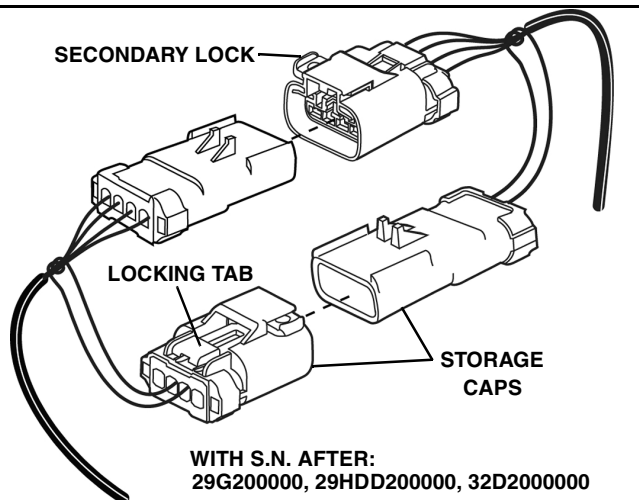

Figure 1-28

10. Disconnect power harness, replace protective caps and back truck away from plow.



WITH S.N. AFTER:  
29G200000, 29HDD200000, 32D2000000

Figure 1-27

# MAINTENANCE

## General

### WARNING

Before servicing plow, lower plow to the ground or onto cylinder lock clamp and disconnect main power harness.

**FAILURE TO FOLLOW CAN RESULT IN INJURY OR DEATH**

- Before operating, perform a through visual inspection of the equipment. Look for fluid leaks, cracked, bent or broken components, loose nuts, bolts or attachments and proper fluid levels.

- A clean system is essential to long pump life and proper performance.

**IMPORTANT:** Hydraulic fluid packaged with power unit is Type 5606. If additional oil is added it must be compatible with Type 5606. If another type of oil has been used in the system the same type of oil must be used for topping off the system.

- Do **NOT** use synthetic oil.
- Oil must contain an anti-foam additive.
- Ensure all electrical connections are clean and tight.
- To prevent rust from forming, clean and repaint exposed metal surfaces.
- **NEVER** operate the equipment with the protective covers or guards removed.

## Break In Period

The plow will go through a break in period during which the A-frame and swing frame will settle in. After 15-20 hours of operation check for free play of the A-frame and swing frame pivot.

1. Raise the plow and install the transport lock. (See "Installing The Cylinder Lock Clamp" on page 12)
2. Push down on end of blade as far as it will go on the right or left side. Measure and record the distance from the ground to the bottom edge of the wear strip.
3. Pull upwards on the same end of the plow as far as it will go. Measure and record the distance from the ground to the bottom edge of the wear strip.
4. Subtract the two measurements. If the number is greater than 1-1/2" then the free play needs to be adjusted.

## To Remove Excessive Free Play

1. Tighten the pivot bolt nut (typically 1/6 to 1/3 turn, one or two flats).

## Periodic Inspection

After every 20 hours of operation perform the following inspections:

1. Inspect plow assembly including sub frame for any damage or excessive wear. Replace parts as necessary.
2. Inspect all fasteners to insure they are properly tightened. Re-tighten loose fasteners to the proper torque. (Refer to torque specification chart in this manual)
3. Apply a small amount of light oil to: Quick-tatch pin and handle assemblies, pivot pins between the blade and swing frame, and pivot pins at lift and swing cylinders. Also lubricate jackstand pins. (See Figure 2-1).

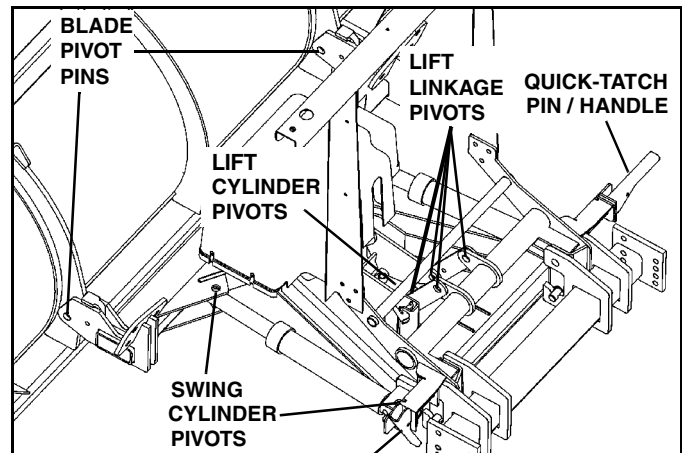

Figure 2-1

4. If wear is noticed between the A-frame and the swing frame apply a good quality anti-seize lubricant to this area.

## Plow Storage

When storing the plow for long periods of time use the following guidelines.

1. If the plow will not be stored on pavement, place a board under the jack stand to prevent it from sinking into the ground.
2. To prevent corrosion, coat the exposed portion of the cylinders with light grease.
3. Grease all pivot points.
4. Fill hydraulic reservoir to the fill line to minimize trapped air.

5. Place dielectric grease on the terminals of all electrical plugs, including those under pump cover. Make sure protective caps are in place or plugs are plugged together.

6. Check and replace any worn or damaged component, such as cutting edges, deflectors, and bushings.

## Polycarbonate Blade Care

- **DO NOT** use abrasive or highly alkaline cleaners on polycarbonate blade.
- **Never** scrape polycarbonate blade with squeegees, razor blades or other sharp instruments.
- Benzene, gasoline, acetone or carbon tetrachloride should never be used on polycarbonate blade.
- **DO NOT** clean polycarbonate blade in hot sun or at elevated temperatures.

## Polycarbonate Blade Cleaning Instructions

Wash with a mild soap or detergent and luke-warm water using a clean cloth or soft sponge. Dry thoroughly with a chamois or moist cellulose sponge to prevent water spots.

## Fluid Requirements

**IMPORTANT:** Hydraulic unit comes from factory supplied with type 5606 hydraulic oil. If additional oil is added it must be compatible with Type 5606.

It is recommended that the fluid in the hydraulic system be changed once a season.

*NOTE: Type 5606 oil is rated to -60 deg. F, when Type 5606 is not available Exxon UNIVIS J13 or equivalent may be used.*

Do **NOT** use synthetic oil.  
Oil must contain an anti-foam additive.

## CAUTION

- **Using the proper oil increases the life expectancy of the most critical part of your plow; the hydraulic power unit.**
- **Failure to use the proper oil can cause extensive damage to the power unit, seals and hydraulic cylinders.**

## Changing Oil and Cleaning Filter Screen

*NOTE: We recommend cleaning the filter screen at every oil change; this will help ensure maximum life and maximum performance from the pump assembly.*

## WARNING

- **Allow the system to cool down before draining oil or handling system components. Burns can result from contact with hot oil.**
- **Never disconnect any hydraulic line or fitting with the plow in the raised position. Always lower the plow and relieve pressure before removing any lines or caps.**

**FAILURE TO FOLLOW CAN RESULT IN INJURY OR DEATH**

1. Move plow to a clean, dry area with a solid surface. Lower the plow to the ground, put vehicle in park, turn off the engine and vehicle ignition, set the park brake, and turn off the plow controller.

2. To prevent inadvertent short circuit or electrical shock, disconnect the power harness and control harness at the vehicle bumper.

3. Loosen the four screws holding on the pump cover and remove the pump cover.

4. Remove the red power lead from the motor power stud. Remove the black wire of the power harness and the black ground wire to the control receiver from the 3/8" screw in the center section of the power unit. Disconnect the 12-pin connector of the power unit valve wire harness. Remove the red/black wire and the red wire of the power harness from the 5/16" terminal of the start solenoid. Remove the red/white wire and the brown wire from the #10 terminals of the start solenoid. Mark wires and terminal locations to aid in re-connecting the wires after the oil change. (See Figure 2-2).

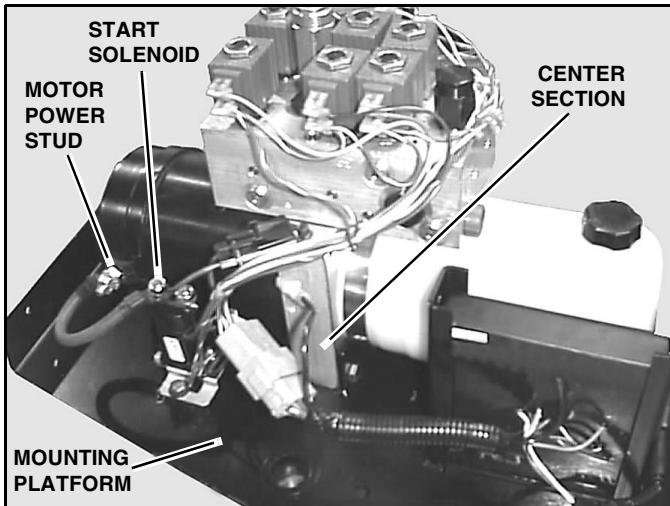

**Figure 2-2**

5. Using a suction gun, drain the oil (most of it) from the power unit reservoir.

6. Remove the two 5/16" cap screws that fasten the center section of the power unit to the pump platform. (See Figure 2-2).

7. Lift the power unit and rotate it toward the rear of the pump platform. (See Figure 2-3).

*NOTE: If the oil has not been previously removed from the reservoir, the power unit can be rotated and tipped to allow most of the oil to be drained out of the reservoir filler hole, once the filler cap is removed.*

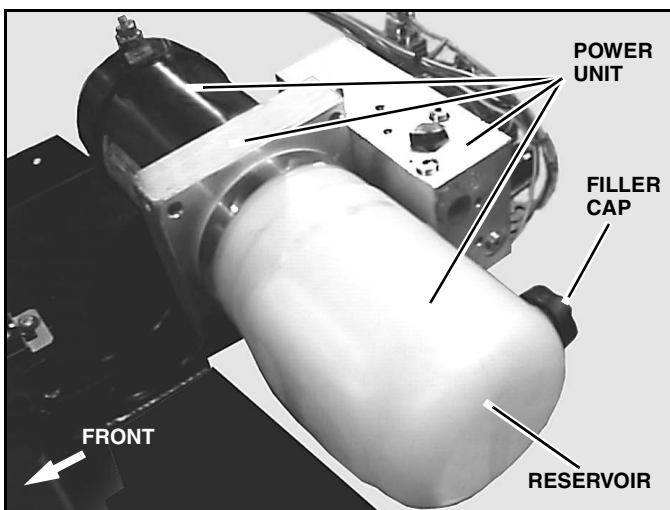

**Figure 2-3**

8. Loosen the band clamp, which holds the reservoir on the center section. Pull and twist the reservoir until it separates from the center section. Place a container under the power unit to catch spilled oil. Note the position of the reservoir oil pick-up tube and be sure the tube is in the same position when the filter is removed and installed. (See Figure 2-3). and Figure 2-4

9. Clean the inside and outside of the reservoir with a suitable solvent.

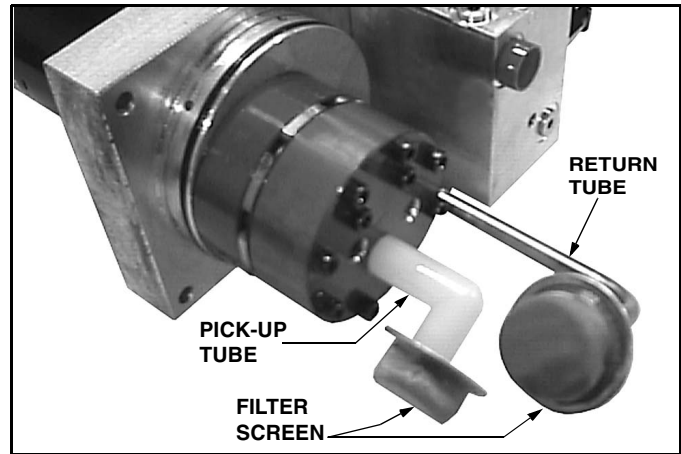

**Figure 2-4**

10. Pull the filter screens from the oil pick up tube and return tube and clean them with a suitable solvent. Blow-dry the filter from the inside with low-pressure air. (See Figure 2-4).

11. Carefully re-install the filter screens. Use care when handling the screens to avoid damage.

12. Inspect the O-ring between the reservoir and the power unit center section and replace it if damaged. Wipe the surface of the O-ring with fresh oil and then push the reservoir onto the center section of the power unit. Be sure to reposition the reservoir so that the oil filler cap is in the same location as before removal.

13. Tighten the band holding the reservoir to 80-120 lb-in. torque.

14. Rotate the power unit back into position. Insert the two 5/16" cap screws. Use new lock nuts and torque to 22-25 lb-ft.

15. Reinstall the electrical wires removed in step 4.

16. Remove the lift cylinder hose(s) from the valve block. Remove the swing cylinder hoses from the fitting in the valve block. Mark hoses before removal to be certain they are reinstalled in the correct location.

17. Place the hoses in a container to catch oil expelled from cylinders. Cycle the lift cylinder by disconnecting hitch pins and pushing and pulling on light bar. Cycle swing cylinders by disconnecting from swing frame and pushing and pulling on cylinder rod.

18. Reconnect swing cylinders and install hitch pins.

19. Reconnect hoses. Lift cylinder hoses are torqued to 20-25 lb-ft and swing cylinder hoses are torqued to 12-15 lb-ft.

## CAUTION

**Do Not use Teflon tape or pipe dope on hydraulic fittings. These can dislodge and jam valves in the hydraulic system.**

20. Fill the hydraulic reservoir with type 5606 hydraulic fluid until the fluid registers full on the sight line.

*NOTE: Vehicle must be parked on level ground and plow must be in lowered position in order to properly check the reservoir level.*

21. Refer to controls manual and cycle plow to remove air from hydraulic system. Refill reservoir as needed.

22. Operate system and check for leaks. Repair and replace components as necessary.

## Cutting Edge

*NOTE: Cutting edge must be replaced when it is worn to the bottom edge of the frame.*

1. Raise the plow to full up position.
2. Install cylinder lock clamp.
3. Lower plow onto cylinder lock clamp.
4. The blade skin must be retained prior to removing cutting edge. This can be done using a pair of 6" C-clamps located at the center of the curved portion of the blade.
5. Remove mounting bolts holding old cutting edge to blade. Discard old cutting edge and hardware.
6. Consult parts manual for proper replacement cutting edge.
7. Install new cutting edge using new hardware.

## Disk Shoe Adjustment

1. Raise plow to full up position.
2. Install cylinder lock clamp.
3. Lower plow onto cylinder lock clamp.
4. Turn vehicle ignition switch and plow control OFF and apply emergency brake.
5. Adjust shoe assemblies by removing shoe mounting lynch pin and adding or subtracting washers on the top or bottom of the shoe-mounting bracket. (See Figure 2-5 or Figure 2-6).

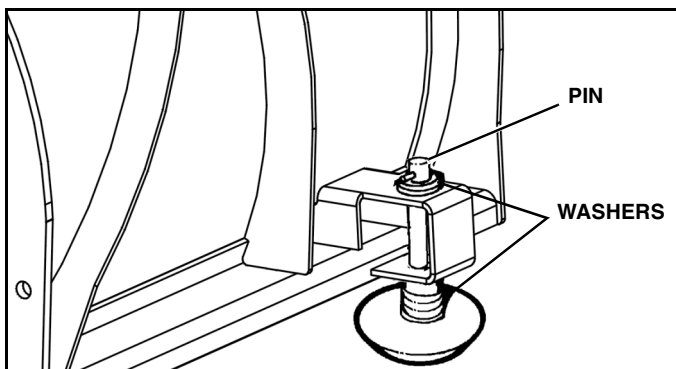

Figure 2-5 (29/32 Series)

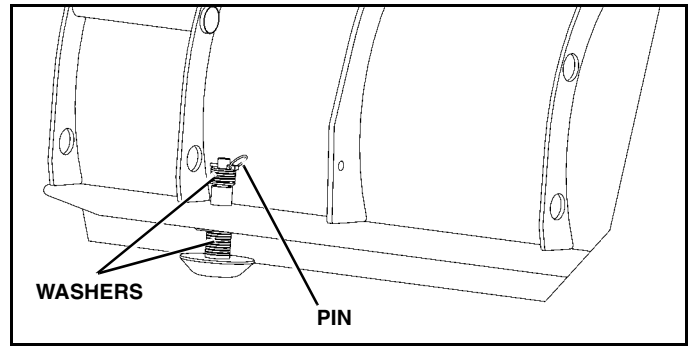

Figure 2-6 (29 HD Series)

6. After the disk shoe position is properly adjusted place washer on the shoe stem - above the disk shoe mounting bracket and below the retaining lynch pin - to remove all up and down movement of the disk shoe in the bracket. Failure to do so will result in excessive wear of the holes in mounting bracket or bending of the disk shoe stem.

**IMPORTANT: Snap lynch pin ring over so that it contacts the pin. If ring does not contact lynch pin, rotate the pin and reverse the direction of the ring. If the ring does not contact the pin it is not locked and could fall out.**

## Trip Spring Adjustment

See "Mechanical Installation" on page 5.

## Emergency Plow Raise

If your snowplow becomes inoperable for any reason, follow the instructions below to raise the plow for transport to your nearest Sno-Way Dealer.

1. Move truck to level hard ground.
2. Place a jack under the swing frame as close to the A-frame as possible.
3. Raise jack until the A-frame is at approximately 30 degrees with the ground.
4. Make sure the plow and jack are stable. Place a jack stand or wood blocking under the A-frame to prevent the plow from suddenly dropping.

## WARNING

**Failure to place a jack stand under the plow could result in the plow rapidly falling.**

**FAILURE TO FOLLOW CAN RESULT IN INJURY OR DEATH**

5. Install cylinder lock clamp. (See Page 12)
6. Remove Jack and Jack stand.
7. Drive to your nearest Sno-Way dealer for service.

# PLOWING OPERATION

## Operating Class

The 29 Series Sno-Way plow is specifically designed for heavy commercial applications on 3/4 and 1-ton trucks. In some applications, the 29 series can be used on 1/2 ton trucks.

The 32 Series Sno-Way plow is specifically designed for heavy commercial applications on trucks with a GVWR of 10,000 to 19,000 lbs. The 8-1/2' and 9' blades can also be installed on many 3/4 ton trucks.

## Before the Season Begins

1. Inspect plow vehicles brakes, headlights, plowing lights, windshield wipers, flashers, electrical system, and cooling system for proper operation.
2. Inspect plow assembly including sub frame for any damage or excessive wear. Replace parts as necessary
3. Inspect all fasteners to insure they are properly tightened. Re-tighten loose fasteners to the proper torque (Refer to torque specification chart in this manual).
4. Apply a small amount of light oil to: Quick-tatch pin and handle assemblies, pivot pins between the blade and swing frame, and pivot pins at lift and swing cylinders. Also lubricate jackstand pins. (See Figure 2-1)..
5. If wear is noticed between the A-frame and the swing frame apply a good quality anti-seize lubricant to this area.
6. Clean and repaint any exposed metal parts with corrosion resistant enamel.
7. Check free play between the A-frame and swing frame pivot. Adjust if necessary. (See "Break In Period" on page 15
8. Check the oil level and repair any oil leaks. (See "MAINTENANCE" on page 15
9. Inspect electrical connectors. Make sure the contacts are clean, and apply a small amount of dielectric grease.
10. Install auxiliary and flashing lights (if not equipped). Ensure auxiliary lights are aimed properly (with the plow raised).
11. If ballast is required, position and secure ballast behind rear wheels, for optimum performance.

## Transporting Vehicle With Plow Attached

1. Always install the cylinder lock clamp when the plow is raised and the operator is not engaged in plowing operations.

*NOTE: If cylinder lock clamp is not installed during transport equipment failure or inadvertent operation of the controls could allow the plow to fall.*

## CAUTION

**Remove the plow when driving extended distances at temperatures above 40 deg. F, the plow blocks enough airflow to cause it to overheat at temperatures above 40 deg. F.**

2. Position the blade out of the beam path of the headlights before driving.

## WARNING

**The 32 Series blade will partially block the plow lights when fully raised. Always lower plow unto lift cylinder lock clamp when transporting plow at night. Blocked plow lights could result in an accident.**

**FAILURE TO FOLLOW CAN RESULT IN INJURY OR DEATH**

3. Do not exceed 45 M.P.H. when driving with the snowplow attached. Braking distance is increased and handling impaired at speeds above 45 M.P.H.
4. Reduce speed when crossing railroad tracks or when road conditions deteriorate.
5. Never change blade angle or height while driving.
6. Inspect plow and attaching hardware for damage before transporting or plowing.

## Plowing Like A Pro

### WARNING

**Wear your seat belt! Contact with a hidden obstruction can cause serious personal injury from bodily contact within the vehicle cab or whiplash from sudden stops.**

**FAILURE TO FOLLOW CAN RESULT IN INJURY OR DEATH**

*NOTE: The air bag is factory set to deploy at a certain acceleration level. The air bag will deploy with the plow attached if an obstruction is hit with enough force to reach this level. Always plow within the recommended plowing speeds and know the area you are plowing to avoid any obstructions.*

*NOTE: For better clean up of hard packed snow; raise the disc shoes so that the cutting edge of the blade comes into direct contact with pavement. Use the lowest possible gear to place maximum power behind the cutting edge.*

For instructions on using the plow controller to manipulate the plow see the manual included with your plow control package.

1. Become familiar with the area to be plowed and mark potential hazards before the snow falls. Many immovable objects cannot be seen when covered with snow. Developing a plan early can save valuable time and equipment damage. Allow sufficient room to pile snow, out of the traffic area, with enough space for when the next storm comes.

2. Plow with the storm. The “Pros” are out early removing only several inches at a time. Allowing snow to accumulate to unmanageable levels can cause removal problems and wear and tear on equipment. The plow is not a “Ram” or a “Bulldozer”. If used properly, it will give many years of safe and reliable service.

3. Research municipal ordinances for restrictions on the disposal of snow. Many municipalities do not allow snow to be placed in or moved across roads or highways.

4. Research state department of transportation rules on maximum width restrictions for snow plows. Certain blades may require permits.

## Using The Down Pressure (DP) Hydraulic Systems

The DP system was designed for removing hard packed snow from hard surfaces that has been driven on prior to

plowing.

The system should be turned OFF when plowing surfaces such as gravel, dirt, sand, etc., to prevent cutting into the surface.

Activating the system applies down pressure to the down pressure side of the lift cylinder. This down pressure will force the cutting edge through hard packed snow. If down pressure decreases as a result of a low spot, more down pressure will be applied to the lift cylinder. When a high spot is encountered the down pressure will be relieved to allow the plow to follow the contour without lifting the front of the truck.

## Clearing Driveways

1. Head into driveway with the blade angled to move snow away from buildings. Continue to widen the drive path by rolling snow away from buildings on successive passes.

2. If there is a garage at the end of the driveway, plow to within several vehicle lengths of the garage and push the snow off the driveway.

3. Raise the blade and drive through the snow up to the garage. Drop the blade and “Back Drag” the snow 1-1/2 vehicle lengths back. Repeat as necessary.

4. Back the vehicle to garage door and plow forward toward street, removing the remaining snow.

## Clearing Parking Lots

### CAUTION

**Excessive stacking of snow causes undue stress to the snowplow and vehicle. Repeated loading of this nature may result in the failure of plow components designed to protect the snowplow and vehicle from major damage.**

1. “Back Drag” areas in front of buildings and near walls then work away from buildings towards the outer edges of the lot.

2. Plow a single path down the center in the longest direction.

3. Angle plow toward the outside and make successive passes until the area is cleared and the snow is “Stacked” around the outer edges. If snow is too deep to clear in the above manner, clear main traffic lanes and stack snow at intermediate positions.

# TROUBLESHOOTING

## Introduction

Whenever service is necessary, your local dealer knows your plow best and is interested in your complete satisfaction. Return your snowplow to your local dealer for maintenance service or any other assistance you may require. If you are unable to do so, this trouble-shooting guide should help you determine the problem. However, before attempting the servicing of your plow, you should possess good mechanical abilities and a total understanding of the mechanism.

PLEASE: Before calling parts and service personnel be certain that:

1. You have read this guide carefully and are certain that all of the suggestions pertaining to your problem have been attempted.
2. You have the following available:
  - A. Date snowplow was originally installed
  - B. Power Pack Serial Number
  - C. Controller Serial Number
  - D. Blade Serial Number
  - E. Pump Serial Number

This information should be recorded on page 2 of this Owners Manual.

## Troubleshooting Quick Reference - General

1. Check vehicle electrical system for proper operation.
2. Check all wiring to be sure that battery terminals are clean and connections to battery, fuse, solenoid, and all connectors on plow harness are clean and tight.
3. Check for external leakage at cylinders, hoses, and power unit.
4. Check the voltage at the coils which operate solenoid valves. For proper operation, ProControl system solenoid coils require a minimum of 10.5 volts DC, while earlier system coils require a minimum of 9.5 volts DC.
5. Check oil level in hydraulic system reservoir.

## TROUBLESHOOTING CHART

PROBLEM	PROBABLE CAUSE	CORRECTIVE ACTION
Motor will not run	Fuse blown	Refer to dealer
	Motor solenoid failed	Refer to dealer
	Motor seized	Refer to dealer
	Motor brushes worn/commutator worn or dirty	Refer to dealer
	Seal between motor and pump damaged allowing oil to enter motor housing	Refer to dealer
Motor continues to run and will not shut-off	Wires shorted out at solenoid or damaged receiver or transmitter	Refer to dealer
Blade will not lift (motor runs)	Hydraulic fluid level low	See Maintenance section
	Improper main pressure relief valve pressure setting or debris causing valve to stick	Refer to dealer
	Breather cap plugged	See Maintenance section
	Lower valve (B) stuck in "Lower" position	Refer to dealer
	Raise cylinder binding	Refer to dealer
	Pick-up tube filter plugged	See Maintenance section
	Worn/failed pump	Refer to dealer
	Pick-up tube is not submerged in fluid	See Maintenance section
	Down pressure valve (E) stuck open	Refer to dealer
Raise valve (C) not functioning	Refer to dealer	

# TROUBLESHOOTING CHART

PROBLEM	PROBABLE CAUSE	CORRECTIVE ACTION
Blade lifts slowly	Hydraulic fluid level low	See Maintenance section
	Breather cap plugged	See Maintenance section
	Improper main relief pressure setting or debris causing valve to stick	Refer to dealer
	Pick-up tube filter plugged	See Maintenance section
	Improper oil viscosity for outside air temperature, unit not at normal operating temperature	See Maintenance section
	Weak system pump	Refer to dealer
	Low battery voltage	Refer to dealer
Unit lifts but does not hold - first action.	Dirt in check valve	Cycle raise and lower system to flush debris
	Dirt in lower valve (B)	Cycle raise and lower system to unstick valve
Unit lifts but does not hold- Second action.	Dirt or debris in check valve	Refer to dealer
	Lower valve (B) sticking or dirt in valve	Refer to dealer
	Seals, O-ring(s) on lower valve (B) damaged	Refer to dealer
	Current available at lower coil (B) without activating function	Refer to dealer
	Piston seals leaking on raise cylinder	Refer to dealer
Unit will not lower (Down pressure switch OFF)	Plugged breather cap	See Maintenance section
	Low or no current available at lower coil (B)	Refer to dealer
	Lower valve (B) sticking or stuck	Refer to dealer
	Lower coil (B) inoperative	Refer to dealer
	Raise cylinder damaged allowing movement in one direction only	Refer to dealer
Unit will not apply Down pressure (Down pressure switch ON)	Lower valve (B) sticking or stuck	Refer to dealer
	Inoperative down pressure, pressure switch	Refer to dealer
	Down pressure relief valve setting to low	Refer to dealer
	Broken wire/ open circuit in down pressure electrical circuit	Refer to dealer

## TROUBLESHOOTING CHART

PROBLEM	PROBABLE CAUSE	CORRECTIVE ACTION
Blade will not angle (motor runs)	Hydraulic fluid level low	See Maintenance section
	Crossover pressure relief valve setting too low	Refer to dealer
	Low or no current available at angle coil (A or D)	Refer to dealer
	Angle coil (A or D) inoperative	Refer to dealer
	Angle cylinder binding or bent	Refer to dealer
	Pick-up tube not submerged in fluid	See Maintenance section
	Angle valve (A or D) not operating	Refer to dealer
Unit angles very slowly	Hydraulic fluid level low	See Maintenance section
	Crossover relief valve pressure setting too low	Refer to dealer
	Improper oil viscosity for outside air temperature, unit not at normal operating temperature	See Maintenance section
	Damaged cylinder	Refer to dealer
	Cylinder packing improperly torqued or dry	Refer to dealer
Unit angles in one direction only	Crossover relief valve sticking or stuck	Refer to dealer
	Angle coil (A or D) inoperative	Refer to dealer
	Low or no current available at angle coil (A or D)	Refer to dealer
	Angle valve (A or D) stuck/sticking	Refer to dealer
	Angle cylinder binding	Refer to dealer
Unit does not hold angle. Note: This problem is usually noted when pushing snow.	Crossover relief valve pressure setting too low	Refer to dealer
	Crossover relief valve sticking or stuck	Refer to dealer
	Pilot check valve has debris or damaged piston	Refer to dealer
Fluid leaking at power unit	Hydraulic fittings not torqued properly (too tight, too loose)	Refer to dealer
	O-rings between valve block and base are worn/ missing or not seating properly	Refer to dealer
	O-rings between base and reservoir worn or not seating properly	Refer to dealer
	Reservoir over-full	See Maintenance section
	Pump shaft seal leaking	Refer to dealer
	Valve block Cap Screws loose	Refer to dealer
	Reservoir fasteners loose	Refer to dealer

# THEORY OF OPERATION

## Hydraulic Power Unit

The hydraulic power unit consists of:

- 12V DC Motor
- Hydraulic pump rated at 1.54 GPM @ 1500 PSI
- 1.35 quart capacity reservoir
- fine mesh intake and return filters
- Filter screens on all outlet ports

The fluid supply line for the pump is submerged in the hydraulic fluid reservoir and is equipped with a fine mesh intake filter screen.

The 12V DC motor is protected electrically by a 250 amp fuse located between the battery and the motor solenoid.

The hydraulic pump is protected by a 2100 PSI system relief valve.

If this unit is equipped with a down pressure option, this will allow the operator to selectively switch the system to provide additional hydraulic force to the cutting edge of the plow.

**IMPORTANT: For proper operation, ProControl system solenoid coils require a minimum of 10.5 volts DC, while earlier system coils require a minimum of 9.5 volts DC. Lower voltage will cause erratic operation, or failure to operate.**

## Hydraulic Controls

The hydraulic controls consist of:

- System pressure relief valve, set to 2100 PSI.
- One crossover relief valve, set to 2400 PSI.
- Two three-way two position hydraulic valves for angle left or right functions.
- Two single acting hydraulic cylinders for angle left and right functions.
- One three-way two position, one two-way two position valve, and one check valve for raise and lower function for gravity plows.
- One three-way two position, three two-way two position valves and two check valves for raise, lower and down pressure functions for down pressure plows.
- One down pressure relief valve for down pressure plows.

## Electro-Hydraulic Operation

All hydraulic functions are controlled by the 12V DC electrical system which energize coils on the hydraulic valve and the power unit motor start solenoid.

Control systems using this style controller (Figure 3-1) when turned ON send +12V DC power to all valve coils.

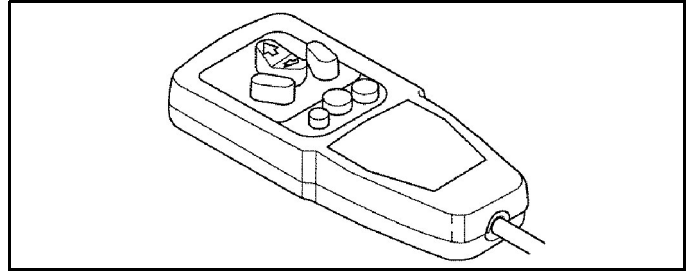

Figure 3-1

ProControl systems (Figure 3-2) directly apply +12V DC power to all valve coils as soon as power is connected to the plow.



Figure 3-2

All systems employ ground switching to energize the hydraulic valve coils. The individual coils are energized as required when the control circuit board or receiver module completes the coil circuit path to ground by means of a signal from the wired or wireless hand-held controller in the vehicle.

## Raise Mode Of Operation

Actuating the 'Raise' switch on the hand-held controller sends a signal to the control circuit board on the plow, which then actuates the motor start solenoid and the coil for the 'C' valve.

Actuating the start solenoid sends current to the power unit motor to cause the power unit to pump hydraulic fluid. Hydraulic fluid under pressure is directed through the 'C' valve to the lift cylinder causing it to extend and raise the plow. On down pressure plows, the 'F' valve is also actuated to allow fluid in the rod end of the double acting raise cylinder to return to the reservoir.

When the 'Raise' switch on the hand-held controller is released, the start solenoid circuit is broken, the motor stops, the circuit to the coil for the 'C' valve and (if a down pressure plow) the 'F' valve is broken and these valves go to their normally closed positions.

## **Lower Mode Of Operation - Gravity Down and Float**

Actuating the 'Lower' switch on the hand-held controller sends a signal to the control circuit board on the plow. This actuates the coil for the 'B' valve and (if a down pressure plow) the 'F' valve, allowing hydraulic fluid to flow from the lift cylinder to the reservoir.

Once the 'Lower' switch has been actuated, the system will stay in this mode until the 'Raise' function is actuated or control is shut off, allowing hydraulic fluid to flow between the reservoir and the lift cylinder. This allows the lift cylinder to extend and retract as necessary to follow ground contours while plowing.

### **Down Pressure (DP) System**

This system operates only when both the 'DP' switch and the 'Lower' switch on the hand-held controller are actuated.

Actuating the 'DP' switch actuates the pressure switch, the 'B' valve coil, the 'E' valve coil and, through the pressure switch, the start solenoid as required. When the 'E' is actuated and the hydraulic pump operates, hydraulic fluid is directed to the rod end of the lift cylinder, retracting the cylinder and forcing the plow down.

The pressure switch in this system senses the pressure of the fluid in the lift cylinder and closes when the pressure becomes low, allowing the motor and the pump to pump fluid into the rod end of the cylinder. When the pressure reaches the proper level the switch opens, shutting off the motor and the pump.

The system is protected by a relief valve, which relieves excess pressure if the plow is forced up, such as by a bump or obstacle in the roadway. Once any obstacle is cleared, the plow can return to a lower position, which will also lower the pressure. If the pressure becomes too low, the pressure switch will activate the motor and pump as mentioned above to return pressure to normal levels.

The down pressure system is overridden any time the plow control is placed in the 'Raise' mode, but will resume when placed back in the 'Lower' position.

Also, note that the 'E' valve is deactivated anytime an angle function is activated, but returns to its previous condition as soon as the angle function is completed.

## **Angle Left or Right Mode of Operation**

Actuating the 'Angle Right' switch on the hand-held controller sends a signal to the control circuit board on the plow. This actuates the start solenoid and the coil for the 'A' valve, allowing hydraulic fluid under pressure to flow through the 'A' valve to the swing cylinder. At the same time, the hydraulic fluid passing through the 'A' valve unseats a check valve in the circuit for the 'D' valve, allowing hydraulic fluid to flow from the opposite swing cylinder through the 'D' valve and back to the reservoir.

Actuating the 'Angle Left' switch on the hand-held controller sends a signal to the control circuit board on the plow. This actuates the start solenoid and the coil for the 'D' valve, allowing hydraulic fluid under pressure to flow to the swing cylinder. This fluid also unseats a check valve in the circuit for the 'A' valve, allowing fluid to flow from the opposite swing cylinder through the 'A' valve and back to the reservoir.

The angle circuits are protected by a crossover relief valve set to relieve pressure on the circuit a 2400 PSI. If the blade of the plow contacts an obstacle during plowing operations, the crossover relief valves will allow fluid to flow out of the swing cylinder on the side encountering the obstacle, allowing the cylinder to retract and allowing the blade to adjust its angle to relieve the force from the outside.

### **Fuse**

A fuse is located near the battery in the primary 12V DC positive power circuit and is in place to protect the electrical system against direct shorts. A high amp draw condition will cause the element in the fuse to interrupt current flow to the plow. The fuse will need to be replaced after interruption.

# MAIN WIRING HARNESS SCHEMATIC (Energy Interruption System)

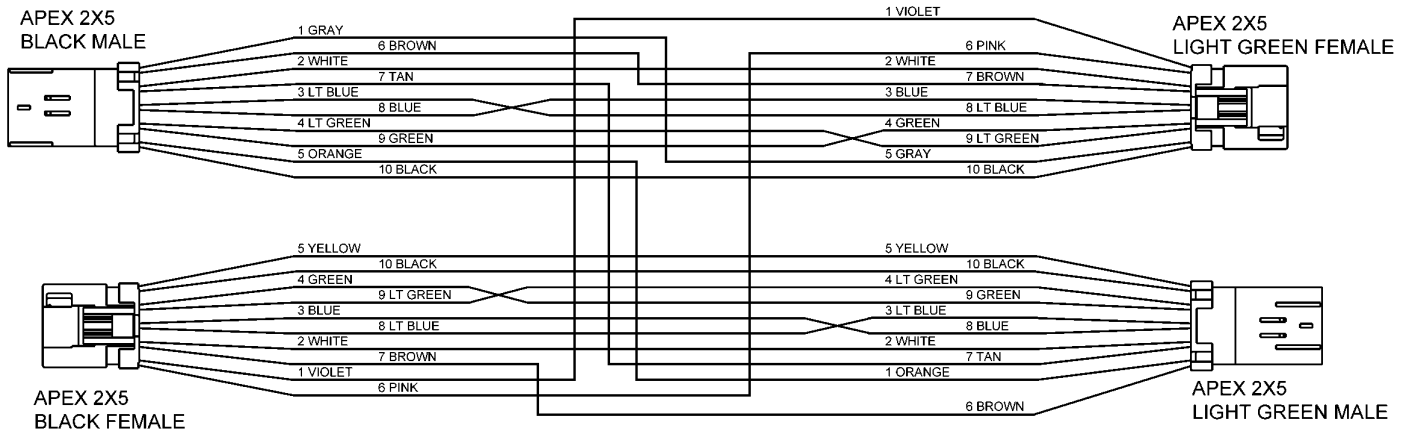

# HYDRAULIC SCHEMATIC (Gravity Down System)

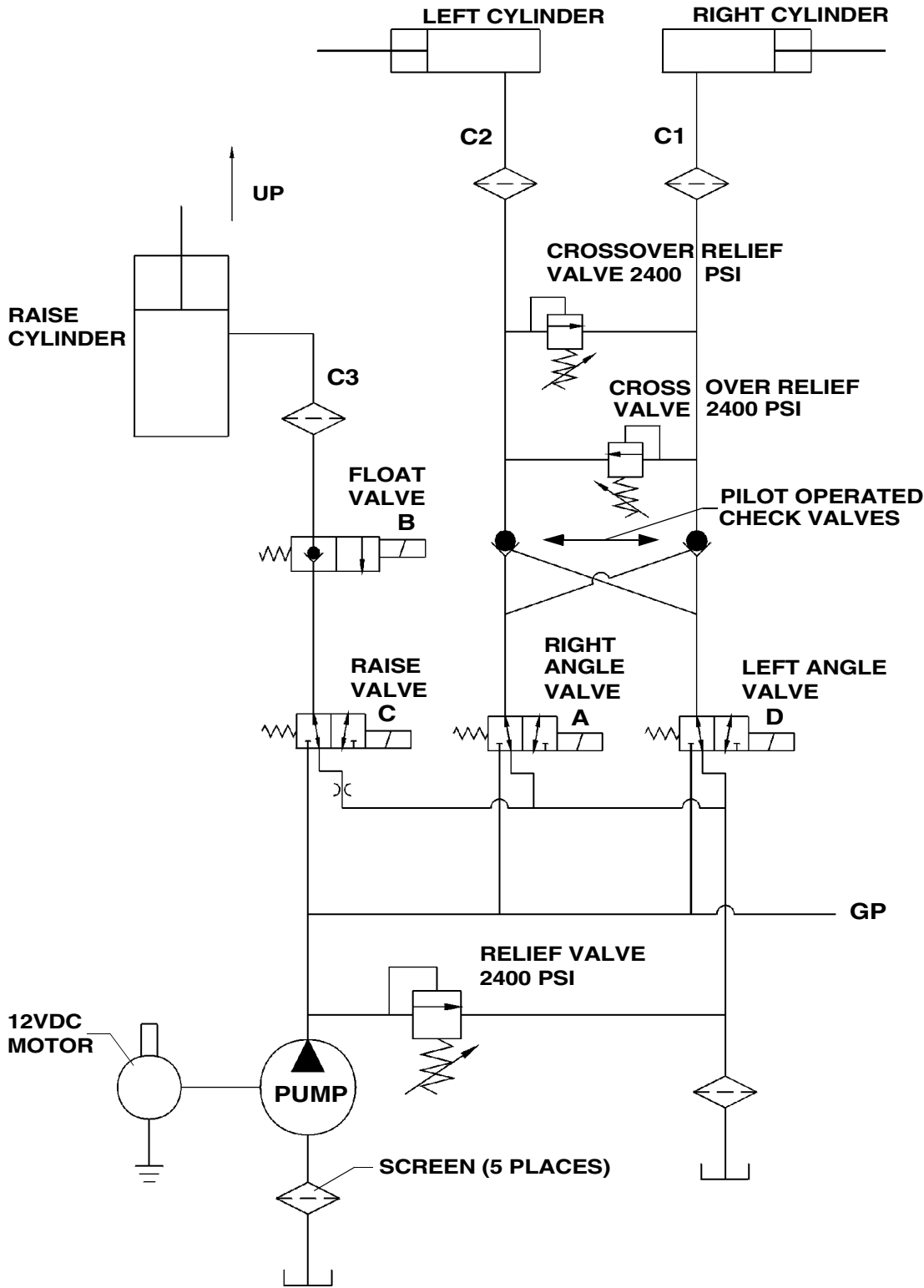

# HYDRAULIC SCHEMATIC (Down Pressure System)

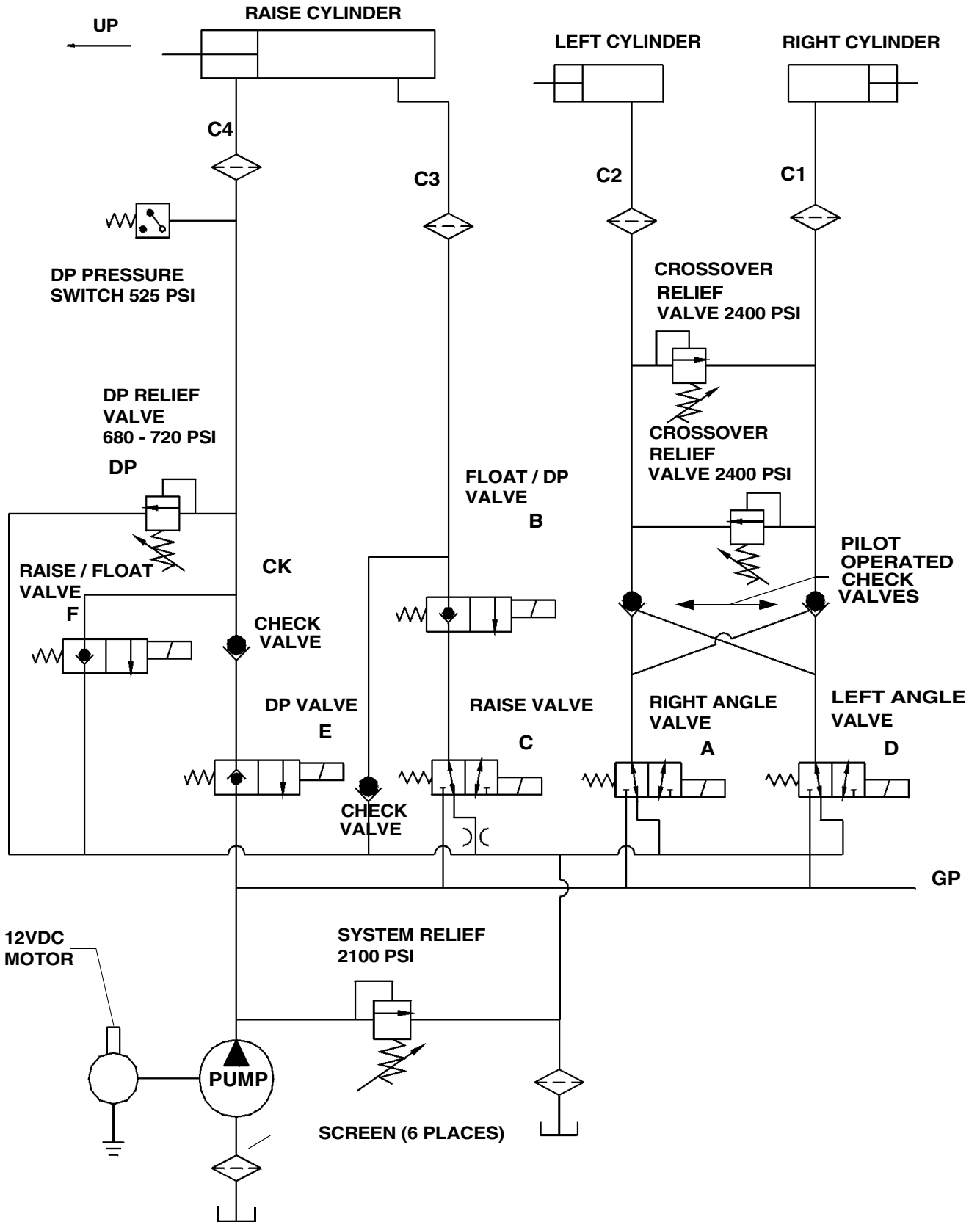

# WIRING SCHEMATIC (Gravity Down System)

With S.N. Before: 29G100300, 29TG100100, 32C100100

RED/WHITE

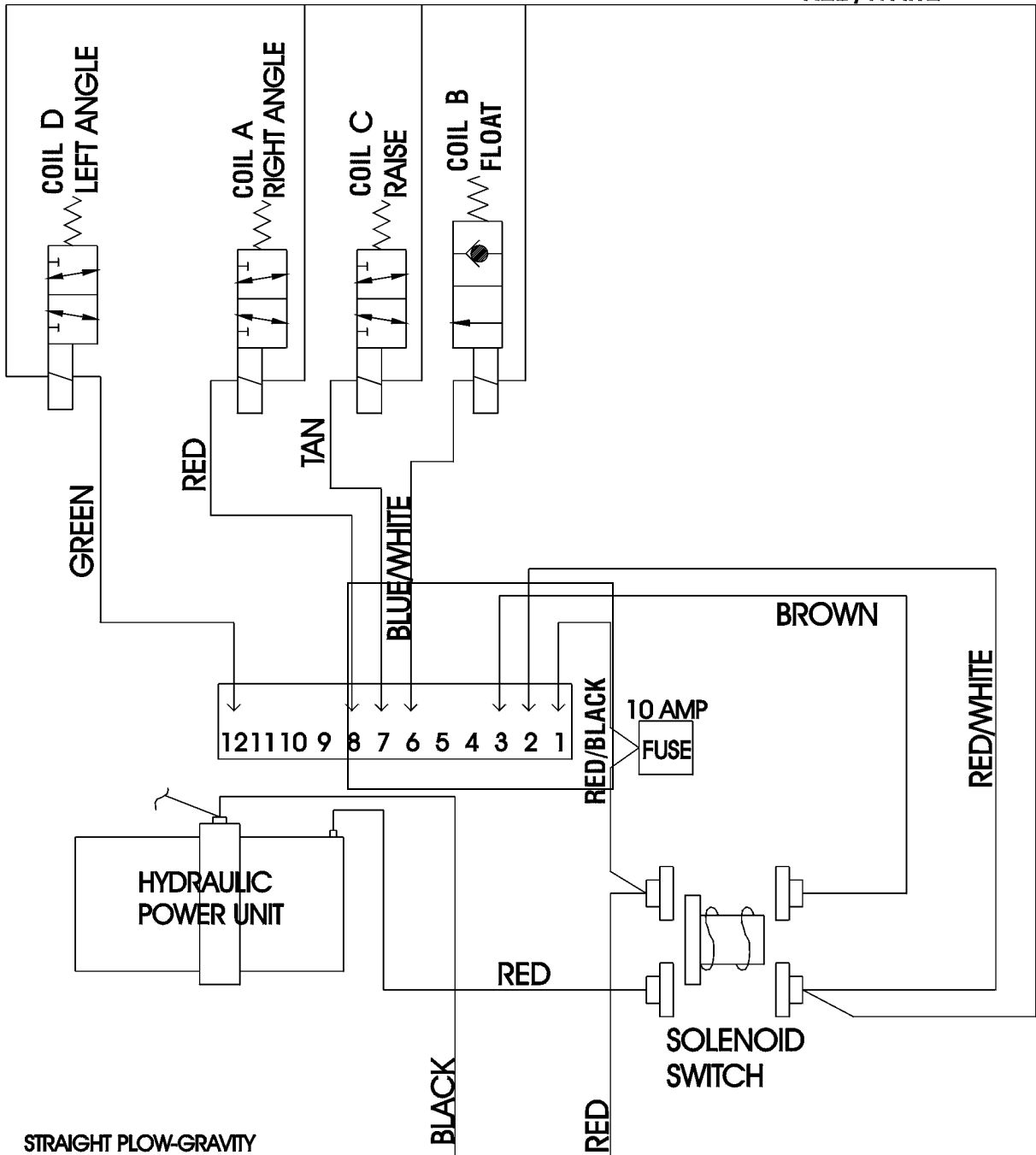

STRAIGHT FLOW-GRAVITY

FLOW FUNCTION	COILS ACTIVATED				
	MOTOR SOLENOID	A	B	C	D
RAISE	X			X	
DOWN (FLOAT)			X		
ANGLE LEFT	X				X
ANGLE RIGHT	X	X			

CONTROLLER STYLE

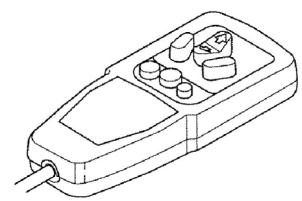

# WIRING SCHEMATIC (Down Pressure System)

With S.N. Before: 29D102300, 29HDD100600, 29TDP100400, 32D102800

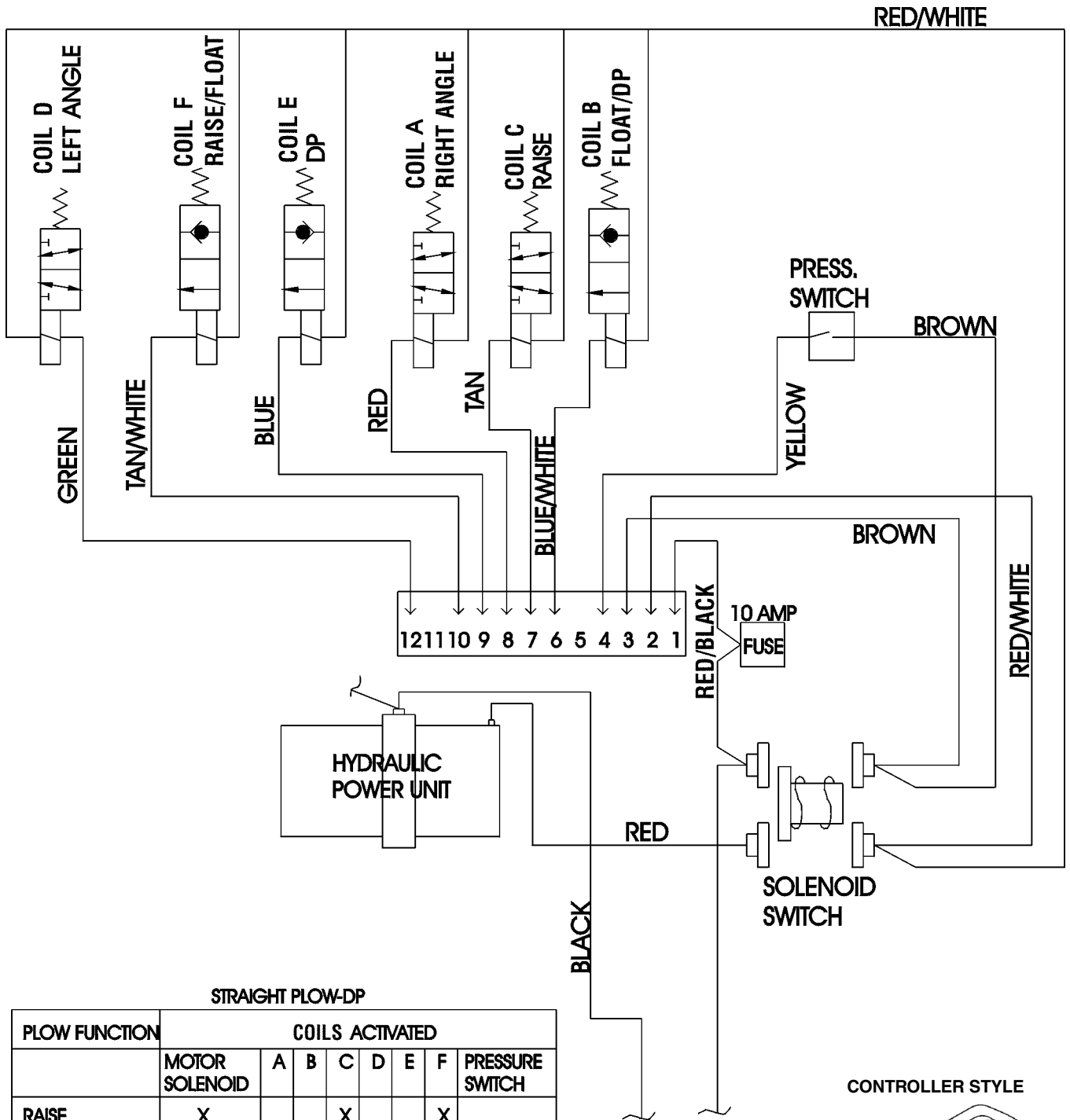

STRAIGHT FLOW-DP

FLOW FUNCTION	COILS ACTIVATED						PRESSURE SWITCH
	MOTOR SOLENOID	A	B	C	D	E	
RAISE	X			X			X
DOWN (FLOAT)			X				X
DOWN PRESSURE	X		X			X	X
ANGLE LEFT	X				X		
ANGLE RIGHT	X	X					

NOTE: COIL E MUST BE DEACTIVATED FOR ANGLE FUNCTIONS

CONTROLLER STYLE

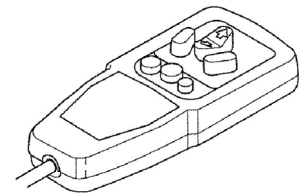



# WIRING SCHEMATIC (Gravity Down System) With S.N. After 29G20000

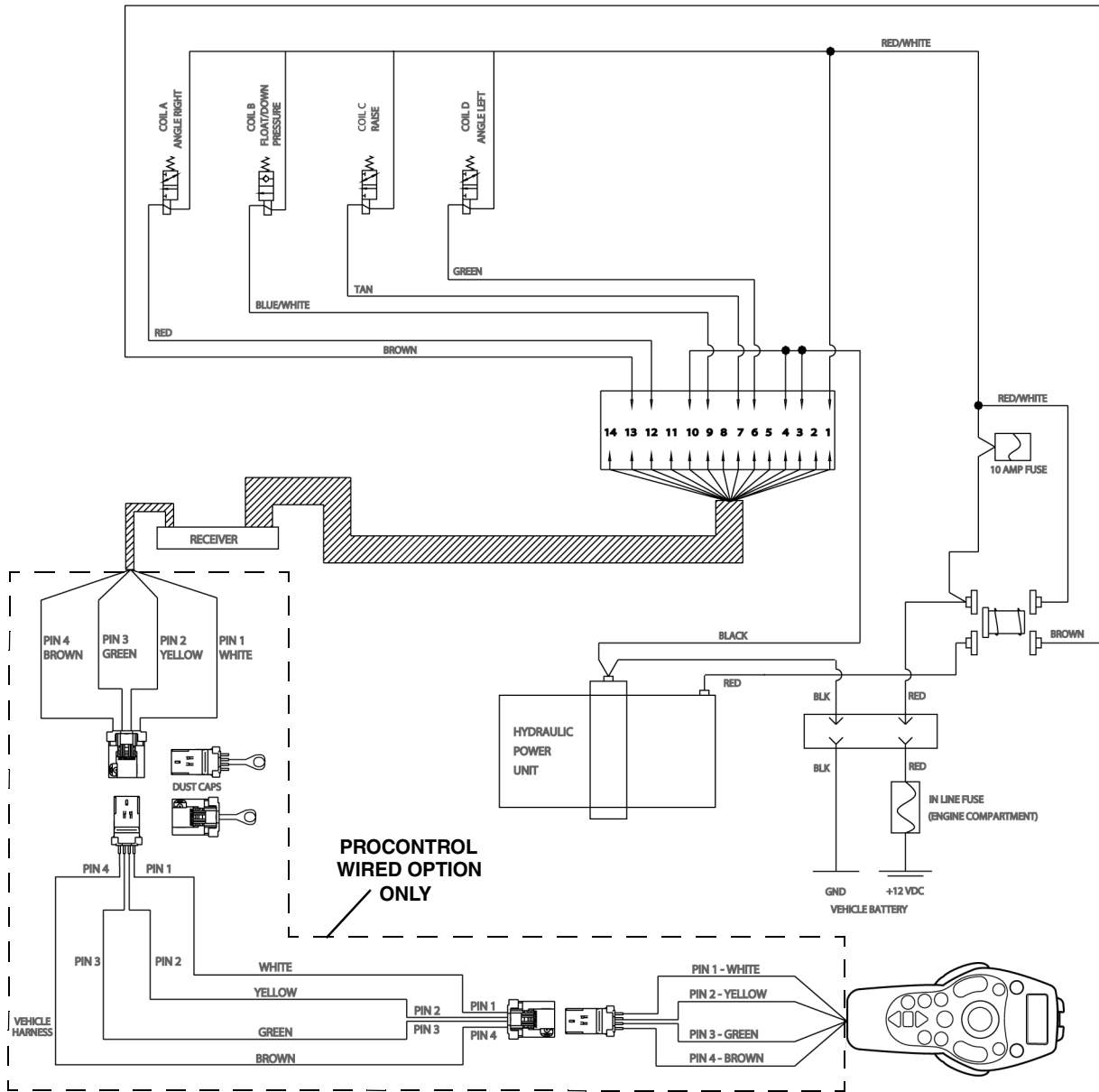

PLOW FUNCTION	MOTOR SOLENOID	A	B	C	D
WIRE COLOR	BROWN	RED	BLUE/WHITE	TAN	GREEN
RAISE	X			X	
DOWN (FLOAT)			X		
DOWN PRESSURE™			X		
ANGLE LEFT	X				X
ANGLE RIGHT	X	X			

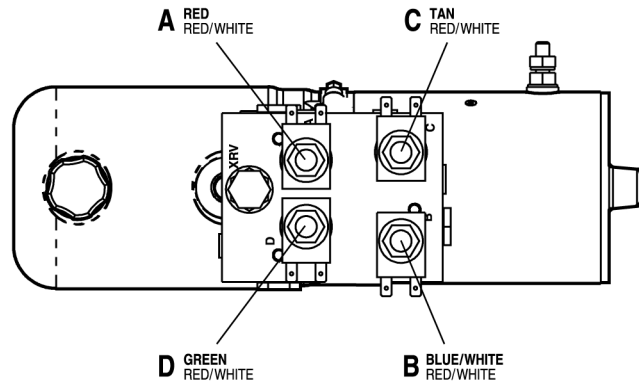



# WIRING SCHEMATIC (Down Pressure System)

With S.N. After: 29HDD200000, 32D200000

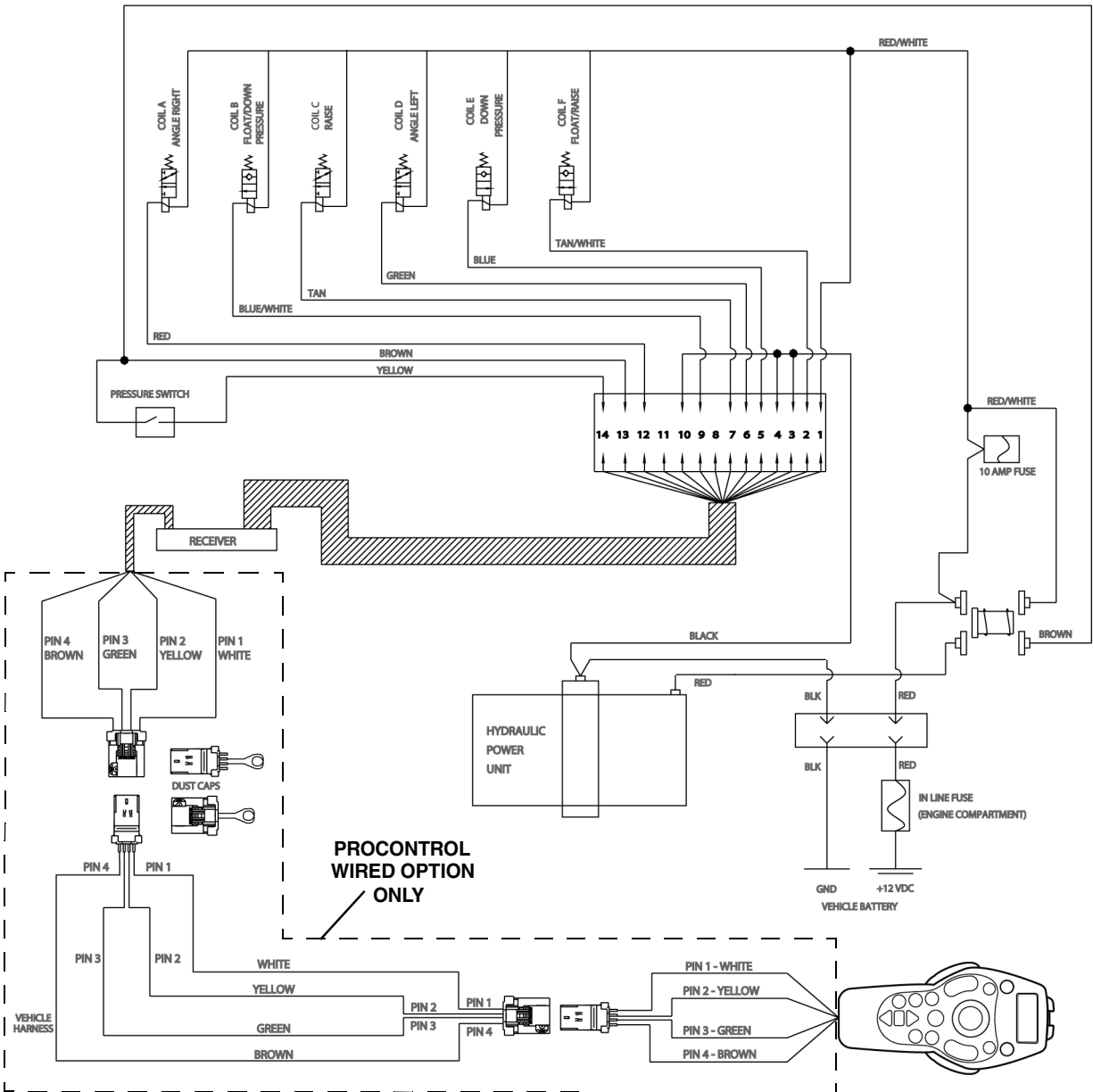



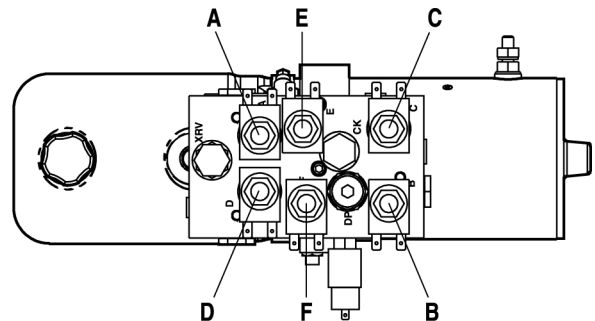



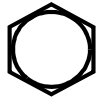

FLOW FUNCTION	MOTOR SOLENOID	A	B	C	D	E	F	PRESSURE SWITCH
WIRE COLOR	BROWN	RED	BLUE/WHITE	TAN	GREEN	BLUE	TAN/WHITE	YELLOW AND BROWN
RAISE	X			X			X	
DOWN (FLOAT)			X				X	
DOWN PRESSURE™			X			X		X
ANGLE LEFT	X				X			
ANGLE RIGHT	X	X						

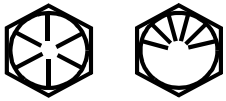

NOTE: COIL E MUST BE DEACTIVATED FOR ANGLE FUNCTIONS

# TORQUE SPECIFICATIONS

SAE Grade and Head Markings	1 or 2 No Marks 	5 5.1 5.2 	8 8.2 
SAE Grade and Nut Markings	2 No Marks 	5  	8  

SIZE	Grade 1		Grade 2		Grade 5, 5.1 or 5.2		Grade 8 or 8.2	
	Lubricated <sup>a</sup>	Dry <sup>b</sup>	Lubricated <sup>a</sup>	Dry <sup>b</sup>	Lubricated <sup>a</sup>	Dry <sup>b</sup>	Lubricated <sup>a</sup>	Dry <sup>b</sup>
	lb-ft	lb-ft	lb-ft	lb-ft	lb-ft	lb-ft	lb-ft	lb-ft
8-32			14*	19*	22*	30*	31*	42*
10-24			21*	27*	32*	43*	45*	60*
1/4	2.8	3.5	4.5	5.5	7	9	10	12.5
5/16	5.5	7	9	11	15	18	21	26
3/8	10	13	16	20	26	33	36	46
7/16	16	20	26	32	41	52	58	75
1/2	25	31	39	50	63	80	90	115
9/16	36	45	56	70	90	115	130	160
5/8	50	62	78	100	125	160	160	225
3/4	87	110	140	175	225	280	310	400
7/8	140	175	140	175	360	450	500	650
1	210	270	210	270	540	675	750	975
METRIC COARSE THREAD			Grade 8.8		Grade 10.9		Grade 12.9	
Grade 8.8			Dry	Lubed	Dry	Lubed	Dry	Lubed
M6-1			8	6	11	8	13.5	10
M8-1.25			19	14	27	20	32.5	24
M10-1.5			37.5	28	53	39	64	47
M12-1.75			65	48	91.5	67.5	111.5	82
M14-2			103.5	76.5	145.5	108	176.5	131
M16-2			158.5	117.5	223.5	165.5	271	200

DO NOT use these values if a different torque value or tightening procedure is given for a specific application.

Fasteners should be replaced with the same or higher grade. If higher grade fasteners are used, these should only be tightened to the strength of the original.

<sup>a</sup> "Lubricated" means coated with a lubricant such as engine oil, or fasteners with phosphate and oil coatings.

<sup>b</sup> "Dry" means plain or zinc plated without any lubrication

\* Values with asterisk are in lb-in.

# NOTES

---

**SNO-WAY® INTERNATIONAL, INC.**

**SNO-WAY**  
**SNOW & ICE CONTROL EQUIPMENT**

Hartford, WI 53027 USA  
Website: [www.snoway.com](http://www.snoway.com)  
©2009 Sno-Way® International



# DEALER PRE DELIVERY CHECKLIST

The following inspections **MUST** be accomplished prior to delivering the snowplow to the customer. Place an X  in the box after accomplishing each item on the checklist.

## CHECK THAT

- Parts have not been damaged in shipment. Repair or replace items that are loose, dented or missing.
- All covers, guards and decals are in place and attached securely.
- All pivot pins and cotters are installed and secure.
- Trip springs are adjusted.
- Shoe assemblies are installed and adjusted.
- Snow plow headlamps are adjusted properly.
- Snow plow headlamps are functional.
  - High Beam                       Low Beam                       Park Lamps
  - Left Turn                       Right Turn                       Headlamp Beam Aimed Correctly
- Cylinder lock clamp is installed.

Start the vehicle engine and place an X  in the box after accomplishing each item on the checklist.

## CHECK THAT

- ALL** blade functions work properly.
- Cylinders, hoses and fittings **DO NOT** leak.
- Listen for abnormal noises or vibrations; Repair or replace as necessary.
- The Power Unit is properly filled.

# DELIVERY CHECKLIST

The following checklist is to be accomplished with the customer present, Place an X  in the box after accomplishing each item on the checklist.

- After giving the Customer his Owner's Manual, instruct him to read it **PRIOR** to operating the Snow Plow. If he has any questions or does not understand part(s) of the Manual, ask him to contact the Dealer for answers or explanations **BEFORE** operating the unit.
- Record the Serial Numbers, Date of Purchase, Purchaser's Name and Address, and the Dealers Name, Address and Phone Number in the space provided on Page 1 of the Owner's Manual.
- Explain mounting and removal procedures.
- Demonstrate power plow controller operation.
- Demonstrate cylinder lock clamp installation.
- Demonstrate Down Pressure hydraulic system function and operation. (If unit is so equipped)
- Fill out Warranty Registration Card and mail COPY 1 to the factory to validate Warranty. NO Warranty claims can be honored if the Warranty Card is not on file at the factory.**

---

SNO-WAY® INTERNATIONAL, INC.



Hartford, WI 53027 USA  
Website: [www.snoway.com](http://www.snoway.com)  
©2009 Sno-Way® International